

# TruLOG™

MAINTENANCE-FREE STEEL SIDING

## STEEL LAP SIDING INSTALLATION GUIDE



**970-646-4490**  
[www.TruLogSiding.com](http://www.TruLogSiding.com)



**USA Made Steel**  
Manufactured in the USA

# Table of Contents

<b>Siding Profile</b>	<b>3</b>	<b>Siding Termination Methods</b>	<b>15</b>
<b>Accessories</b>	<b>4</b>	<b>Steel Siding Cutting</b>	<b>16</b>
<b>Tools &amp; Equipment</b>	<b>7</b>	<b>Panel Installation</b>	<b>17</b>
<b>Cutting Tools</b>	<b>8</b>	Row One	17
<b>Fasteners</b>	<b>9</b>	Panel Laps	17
<b>Preparation</b>	<b>10</b>	Expansion and Contraction	17
House Insulation and House Wrap	10	Proper Siding Staggering	18
Surface Preparation (If Needed)	10	Hanging of Siding	18
Window Sill Preparation (If Needed)	10	Screws	18
Straitline	11	Power Nailers	18
Level	11	Panels at Window (Bottoms)	19
		Panels at Windows and Doors (Tops)	19
		Gable End Measuring and Cutting	19
<b>Accessory Installation</b>	<b>12</b>	Installing	20
Starter Strip	12	Subsequent Rows	20
Elevation Change	12	Final Row of Siding Under Eaves	20
Alternative Starter Methods	12	Replacing Damaged Panels	20
Window and Door J-Channel	12	Clean Up	21
Flashing	13	Job Site	21
Inside Corners	13	Additional Tips	21
Expansion for Inside Corners	13		
Bold Window and Door Trim	14		
Two Piece O.C.P. Installation	14		
J-Block Installation	14		

# Steel Lap Siding Profile

## 9.25" Steel Lap Siding Profile

Our steel lap siding covers 9.25 inches high on the wall and the panels are 12 ft in length. Our metal lap siding product offers the look of a rustic home while providing maximum durability and easy upkeep. Steel Lap Siding by TruLog has a genuine wood appearance but requires no care other than an occasional rinse with the garden hose.

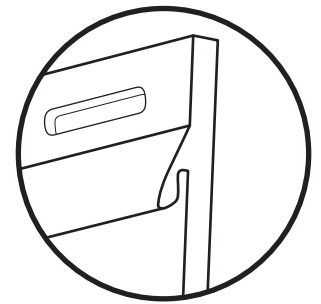
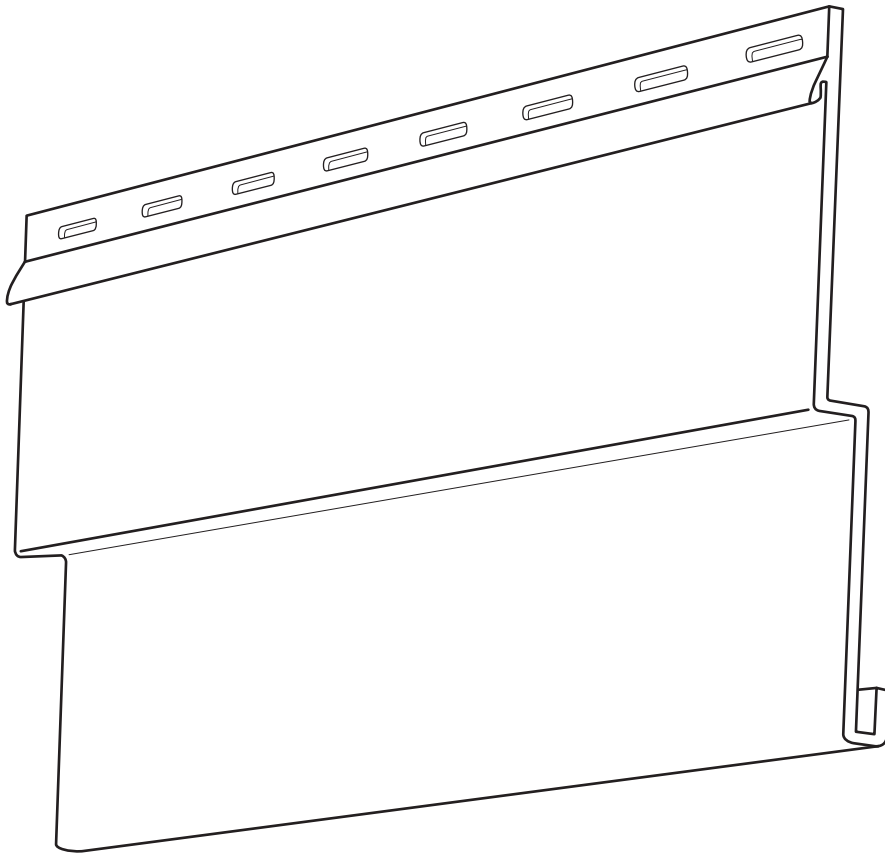

Nail Strip  
& Top Lock

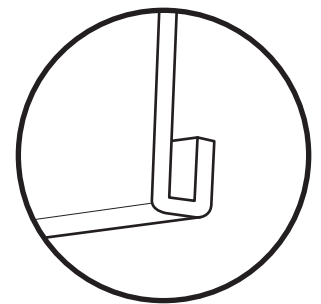

Bottom Lock

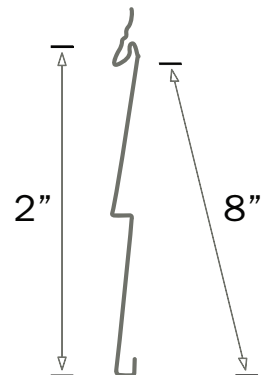

# Lap Color Matched Accessories

## Starter Strip

Starter strip is the first siding accessory you will install on your structure because it is the starting point for your whole installation. On most applications, a starter is used at the lowest point of your structure and will hang down over the top of the foundation  $\frac{1}{2}$  inch. The starter is used to lock the first panel of our metal lap siding to your structure.

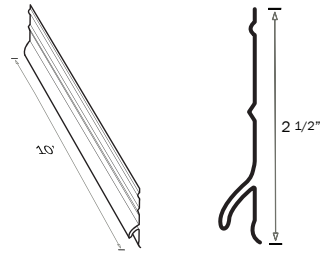

## J-Channel

The J-channel is used in various places but is mostly used to trim around doors and windows to accept siding in those areas. You can also use the j-channel to terminate our siding at the soffit level, use it for inside corners by butting two j-channels together, on top of decks or patios where there is an elevation change, on a roof line, and numerous other places. The J-channel is used to hide cut edges of the siding and is nailed or screwed 12 inches on center.

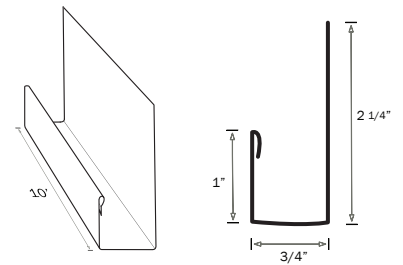

## Sill Trim/Undersill/Utility Trim

Sill trim is primarily used to stiffen our siding panel when either the top or bottom lock is cut off. It is used to strengthen the cut edge to maintain rigidity. It is mostly used above and below doors and windows where siding needs to be trimmed to fit. If you ordered our bold window and door trim you don't need to use a sill for this application. It can also be used on elevation changes and/or terminating the siding at the soffit level on your straight runs or eaves.

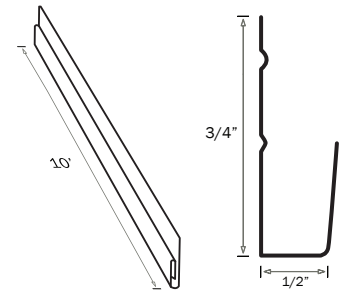

## Frieze Board (Crown)

Frieze board is one of the last siding accessories to install on your home. Frieze board is used where the top metal siding panel meets your soffit. Normally, you would have to cut the siding almost perfectly or install another piece of j-channel to accept the siding. Not anymore with frieze board! This L-shaped metal crown snaps directly into the soffit j-channel and covers up your cut lap siding. Eliminate the need to cut the siding to exact lengths by using the frieze board to cover cut ends. If you do not have metal or vinyl soffits, we can provide a "keeper" system that will screw into the wood soffit or composite soffit to act as the attachment point for the crown.

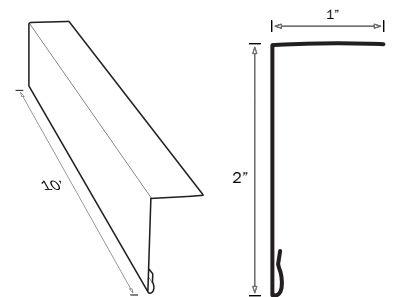

## Corner Base & Cap

Corner bases and caps are used to cover up the corners of your house and hide the cut metal siding. A corner base is applied to the home so the corner cap can be snapped on over the top. Corners provide your home with a great finished look as well as protects the end of your TruLog™ siding.

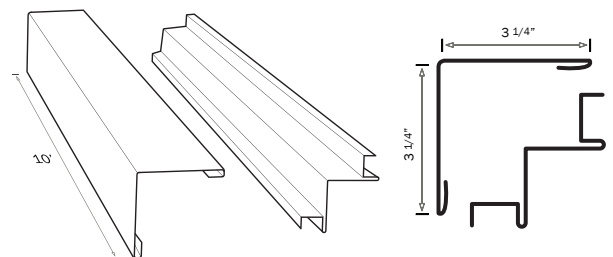

# Lap Color Matched Accessories

## Bold Window & Door Trim

Bold window and door trim is an optional trim piece that gives your doors and windows a bold and finished look. This trim piece is installed after all of your siding is up and you are ready to finish the installation. You will still need to use a j-channel around your doors and windows and then slide this trim piece in between the window frame and the j-channel for a tight, friction hold. You can also run a bead of caulking on the inside leg of the bold trim, before installing it in between the j-channel and window frame, for extra holding strength. Once in place, use a bead of caulking where the bold window trim and window frame meet for increased holding strength.

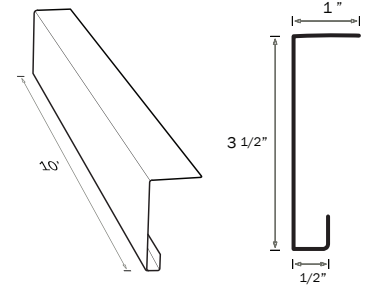

## Rock Transition (Z-Flashing)

Rock transition or “Z-flashing” is used to transition from any rock or stone walls to our steel lap siding. It is mainly used to divert water up and away from the rock or stone but is also used as a transition point for the steel lap siding to start on.

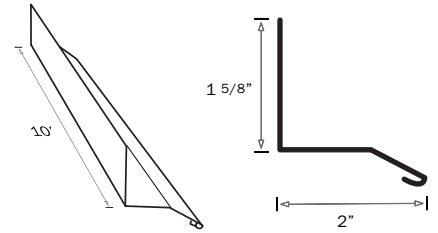

## Custom Trim

If you have a specific trim piece in mind that is not listed in this guide, we can bend one for you if you provide the dimensions of the piece.

## Trim Coil

If you are wanting to bend your own custom trim pieces on the job site, we can provide you with color matched steel coil. Keep in mind our steel is 26 gauge and will take a mini 5 clamps on your sheet metal brake in order to bend it.

## Utility J-Block/Split Mini

Utility J-blocks are used to trim around your outlets or spigots. The back of the J-block can be cut to fit either of these profiles. You fit the exterior penetration, install siding around it and snap the beauty ring over the top. It is a 2-piece system making siding around these areas much more simple.

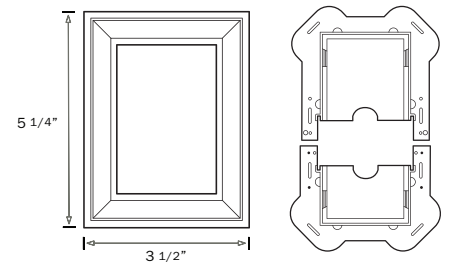

## Light J-Block

Light J-blocks are used to mount your lights to using a simple base and cap system. First you attach the base, then pull the wires through, then install siding around it, and snap the beauty ring on. Finish by mounting your light over the top of the raised base.

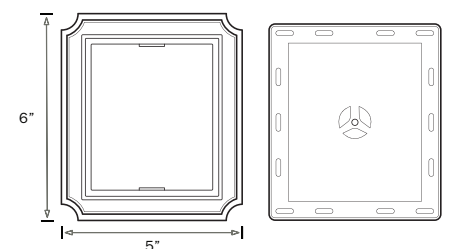

# Lap Color Matched Accessories

## Dryer Vent

The dryer vent is another j-block that helps simplify siding install. The Dryer Vent comes with a metal 4" tube that slides into the house, siding is installed around it, and then a beauty ring is snapped on over the top.

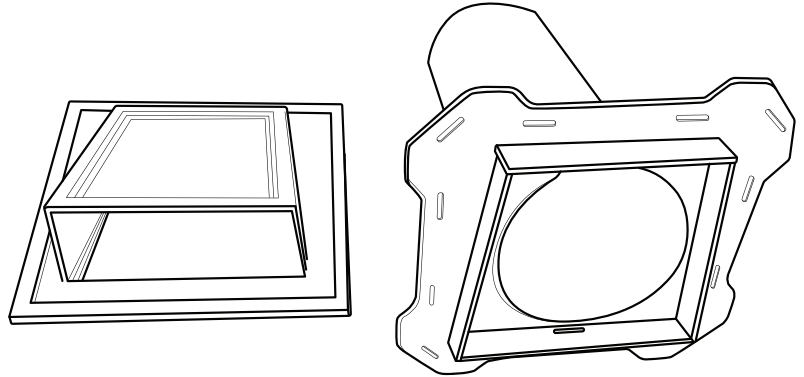

## Exhaust Vent

Exhaust vents are used for bathroom fans, furnace fans, and other applications. The Exhaust Vent comes with a metal 4" tube that slides into the house, siding is installed around it, and then a beauty ring is snapped on over the top. Exhaust Vent is identical to the Dryer Vent but has flaps instead of a hood for the opening.

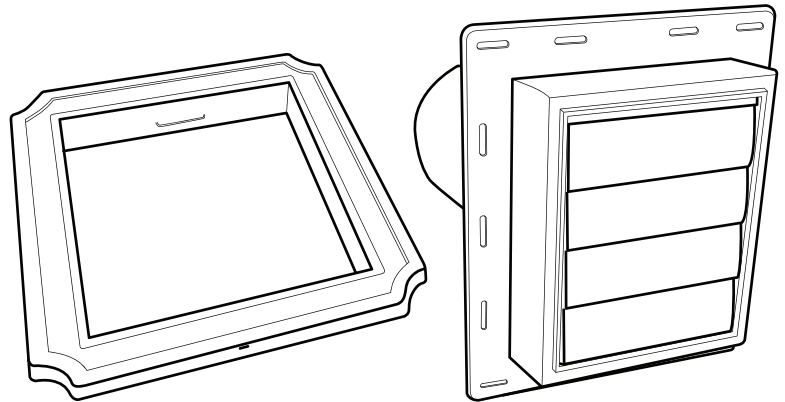

## Jumbo J-Block

Jumbo J-blocks are used to mount your lights to using a simple base and cap system. First you attach the base, then pull the wires through, then install siding around it, and snap the beauty ring on. Finish by mounting your light over the top of the raised base.

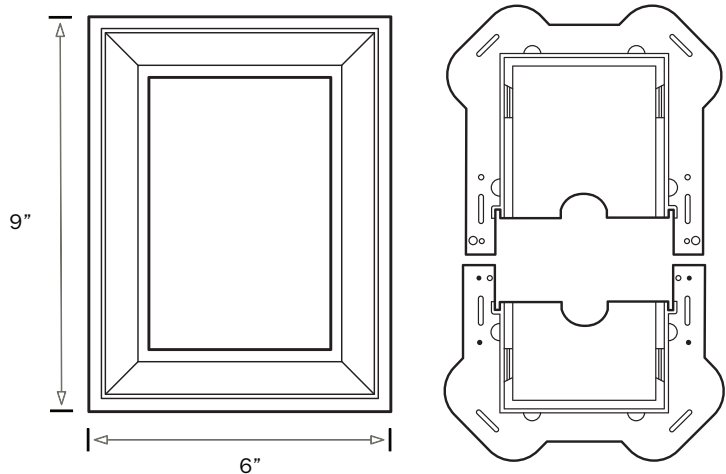

# Tools and Equipment

## Tools

### Helpful Tools for Installation

- Hammer
- Level
- Tape Measure
- Power Saw (with steel sheet metal blade)
- Electric Shears
- Utility Knife
- Drill
- Prybar
- Safety Goggles
- Aviation Snip
- Flathead Screwdriver
- Caulk Gun
- Speed Square
- Needle Nose Pliers

### Additional Tools for Installation

- Trim Coil
- Touch-up Paint
- 1" - 1 1/2" Galvanized Fine Thread Screws or Nails
- 1" to 1 3/4" Steel Trim Nails
- Nail Punch
- Butyl or Urethane based caulk

## Equipment

### Siding Cutting Table

This table allows for a normal circular saw to be used with the proper steel blade to cut siding and soffits. It is especially helpful for angled cuts on peaks and rakes. These tables are lightweight, portable, and can be set up and moved by one person with ease. These tables also allow for the saw to be away from the siding when being cut, which allows for fewer scratches or damage to occur to the siding panels.

**\*Always make sure to wear protective safety glasses and gloves when cutting/handling steel siding.**

**\*Follow safety instructions that accompany your tools/blades and wear the suggested protective gear.**

# Cutting Tools

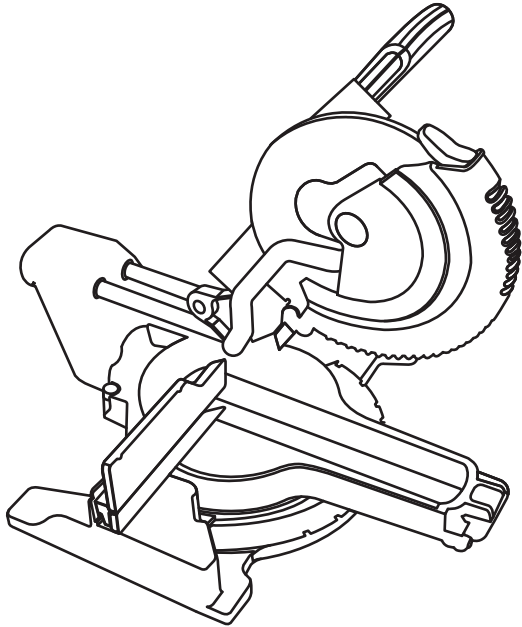

## Sliding Miter Saw with Ferrous Metal Cutting Blade

We recommend brands such as:

- Diablo
- Tenryu
- Irwin

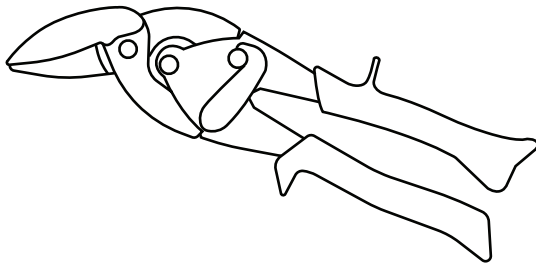

## Steel Snips or Hand Snips

We recommend Midwest Left & Right  
Offset Aviation Snips.

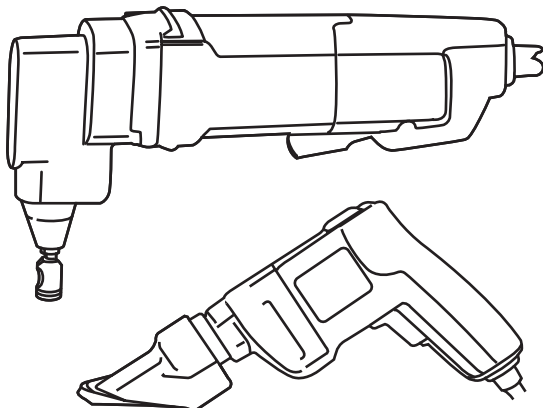

## Nibblers or Electric Shears Stand Alone Tool or Drill Attachment

We recommend brands such as:

- Dewalt

# Fasteners

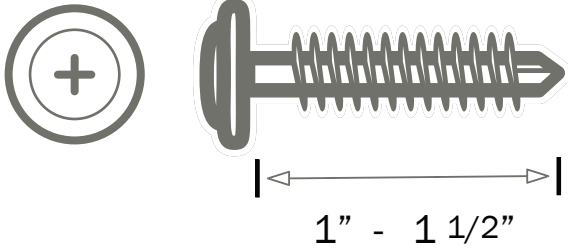

## Galvanized or Anodized Screw

A screw with fine threads from 1" - 1 1/2" inches in length.

We recommend:

- Grabber Fasteners
- Bugle Head Phillips Gold Screw
- Comparable screw with similar length and profile to the above.

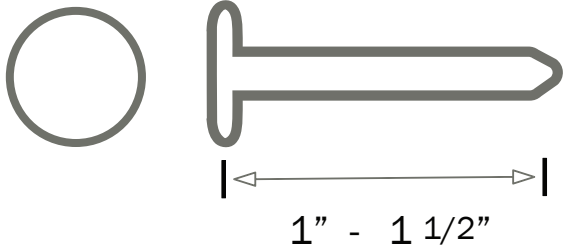

## Carpenter Nails

Any Carpenter nail will work fine.

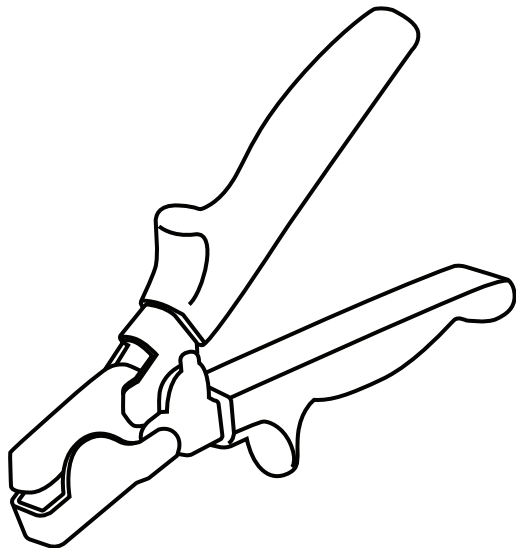

## Snap Lock Punch/Notching Tool

You will need a notching tool if you order our crown/frieze board termination tool. This tool is used to punch a notch in the leg of the crown so you can snap it into a soffit J-channel made out of either metal or vinyl.

\*Used only if you purchased our frieze board/crown trim piece.

We recommend:

- Malco SL-1 Snap Lock Punch

# Preparation

**TruLog steel lap siding needs to be installed on a flat wall surface in order for the panels to interlock and overlap correctly. If you do not have a flat wall surface, you will need to create one by furring out the wall with foam, OSB board, or furring strips, whichever makes the most sense to you. Make sure to level out the wall as best you can before starting the siding.**

## House Insulation and House Wrap

For the typical siding application house wrap or sheet insulation can be placed on the exterior of the wall right over the OSB or plywood. House wrap will prevent drafts from occurring and will also shed any moisture that may get behind the siding. We recommend Tyvek brand house wrap since it is woven more tightly than other brands. If insulation is needed this should be installed over the OSB/Plywood and under the house wrap (**Figure 10.1**).

## Surface Preparation (If Needed)

Remove and replace any rotted or damaged boards. Check for waves in the wall and shim out (or build out) if necessary. Nail or screw down any loose boards or trim. Scrape away any old caulking, especially where it may interfere with the new trim pieces (windows and doors). New caulking should be installed to seal any air leaks where old caulk was removed. Remove or loosen objects that may be in the way of the new siding (downspouts, cables, planters, shutters, house numbers, mailboxes etc.). If meter boxes or power lines must be removed contact a local professional. Best practice is to remove the old siding before installing TruLog™ Steel Siding.

## Window Sill Preparation (If Needed)

Window sills may be cut off flush with the vertical window casing to allow the J-channel to be installed flush with the casing. Coil stock can then be installed around the window casing and sills using a brake. Flashing may be prepared under the window to keep water from getting behind the siding. If you are installing siding on a new structure with new windows, butt your J-channel tight to the window frame and follow the J-channel instructions. If you are installing bold window and door trim in addition to the J-channel, follow those instructions as well in (**Figure 10.2**).

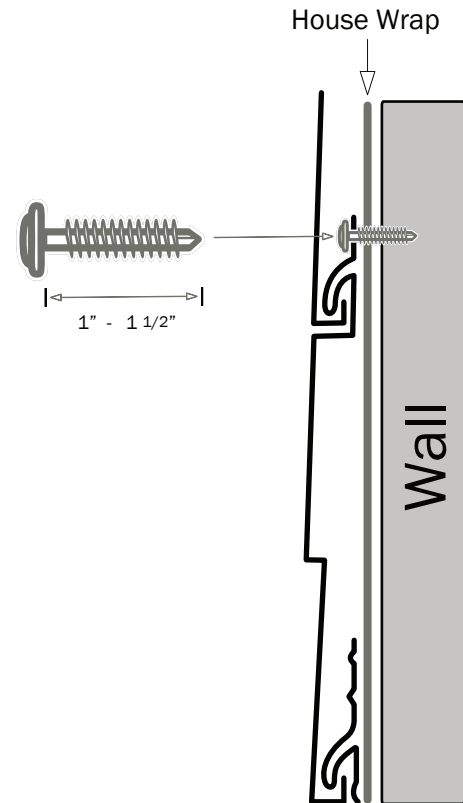

Figure 10.1

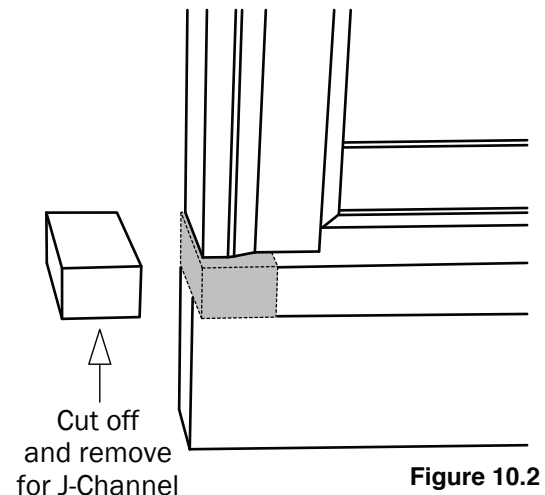

Figure 10.2

# Preparation

## Straightline

A chalk line is a good way to start an installation. Often times this is used to develop a reference line as to which the starter strip can be installed. We recommend measuring equal distances down from the eave line, or from the window sills that are at the same height (**Figure 11.1**). This line allows for the siding to be run parallel with the eaves or windows which gives the appearance that the siding is running level regardless of the actual levelness of the house or ground.

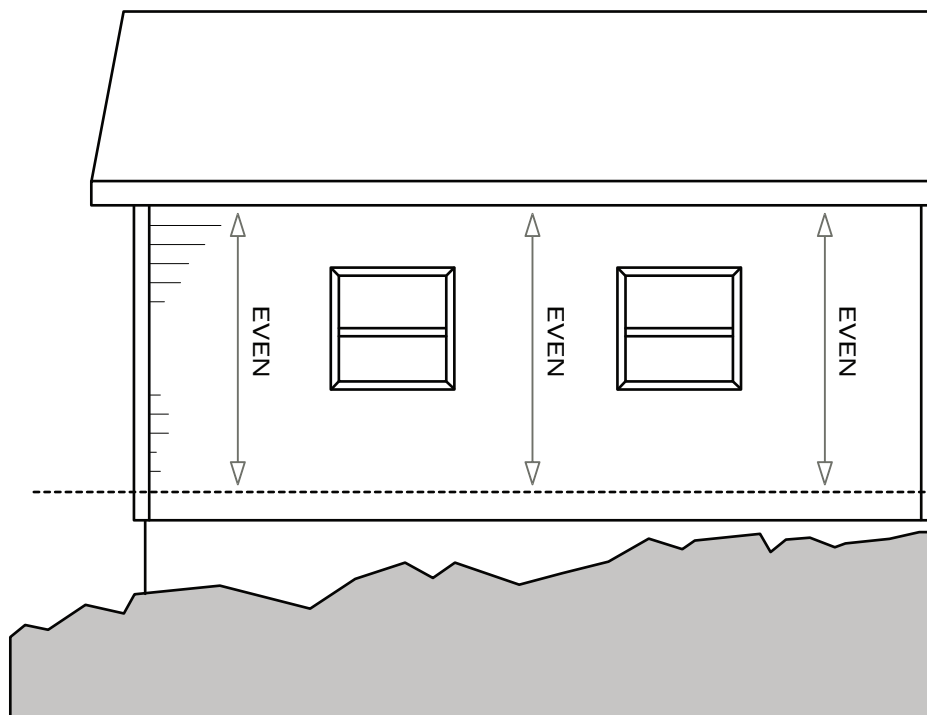

Figure 11.1

## Level

Another good way to start an installation is to check if the walls are level. If the walls are reasonably level a chalk line and level may be used to determine a line for the starter strip to be installed. This is done by driving a screw at the desired height for the top of the starter strip. Then connect the end of the chalk line to the nail and pull it to the opposite end of the wall, making sure to pull the line tight. Then use a level in the middle of the line to determine where the chalk line should be snapped. Be sure there is no sag in the line when it is snapped, this can easily occur when the line is stretched over 20'. Continue this process on all sides of the building making sure the line matches up on all sides. This is very important as this is the basis for all subsequent rows of siding.

**\*It is recommended to use a level 4' or longer in this process and also to take level readings at the center of the line.**

# Accessory Installation

## Starter Strip Installation

For most projects, you will use the starter strip at the lowest elevation on your structure. Your starter should be a  $\frac{1}{2}$ " below the top of the foundation. Put the top of your starter strip on the level chalk line you made from the previous "Leveling" step. This will insure you have a level starting point for the siding. Be sure to install the starter strip with screws spaced no more than 12" O.C. **(Figure 12.1)**. Overlap the corner nail flanges (inside & outside), this will help reduce any air leaks. Be sure to screw the starter strip as low as possible, this will provide extra rigidity to the bottom row of siding.

Do not overdrive screws to prevent distortion. Butt starter strips to each other. Starter strips can be cut with tin snips when shorter lengths are needed.

If your lowest elevation is above rock/brick wainscoting, you will need to install your rock transition trim piece first then your starter strip on top.

If your lowest elevation is on top of a deck, you will need to install your L-angle trim piece first then install a starter strip on top of it, leaving  $\frac{1}{2}$ " to  $\frac{3}{4}$ " of an inch spacing in order to lock the panel in.

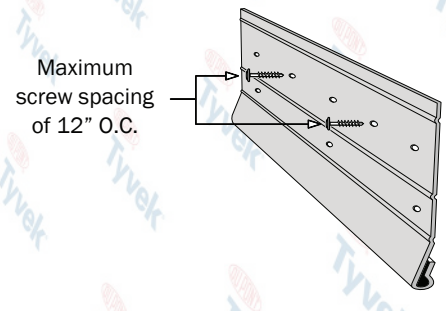

Figure 12.1

## Elevation Change / Other Starter Methods

If you run into a situation where you need to go over a porch, deck, patio, or elevation change up from your original starter point, you will use a J-channel and sill trim as your starting point instead of a starter strip. This occurs because you will rip the bottom of your panel down so you can keep the same profile height all the way around the building **(Figure 12.2)**.

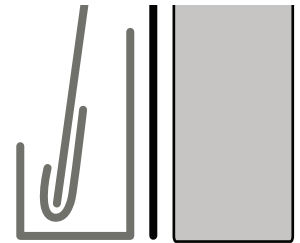

Figure 12.2

## Window and Door J-Channel Use

J-channels need to be installed around windows and doors **(Figure 12.3)**. This is done so the butt end of the siding can be slipped into the J-channel opening. The side pieces of J-channels are left  $\frac{3}{4}$ " above the window top, and  $\frac{3}{4}$ " below the window sill. The bottom of the J-channel has a V-groove notched out of the back side and nail flanges ( $\frac{3}{4}$ " depth). This allows for the siding to slip into the finish trim and hide the cut of the finish trim.

The top of the J-channel has the back side notched out  $\frac{3}{4}$ ", leaving the face and nail flange in place. The top J-channel is cut to fit from outside to outside of the side J-channels. A  $\frac{3}{4}$ " slit is cut into the corners of the J-channel and top is folded down inside the side J-channel pocket. Be sure to put the face of top J-channel over the face of the side J-channel. Drip caps need to be installed before the J-channel at the top of the windows and doors. L-channels should be used in this application.

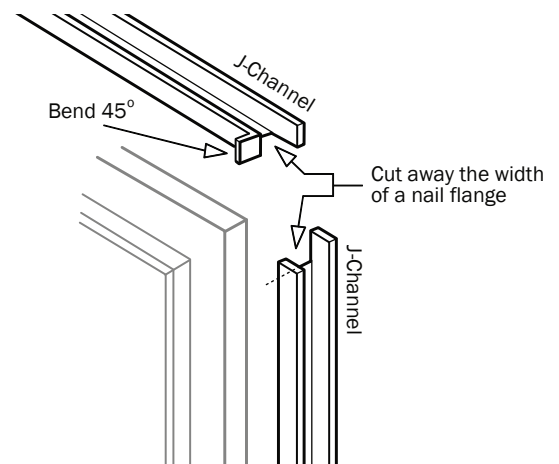

Figure 12.3

# Accessory Installation

## Flashing

It is a good idea to install window tape over existing window nail flanges (**Figure 13.1**). Also you may install a piece of window tape or coil stock under the nail flange of the side J-channels and lap over the nail flange of the siding panel directly under the window or opening. This will allow water to run over the top of the siding and out the weep holes in the bottom of the siding instead of behind the siding panel.

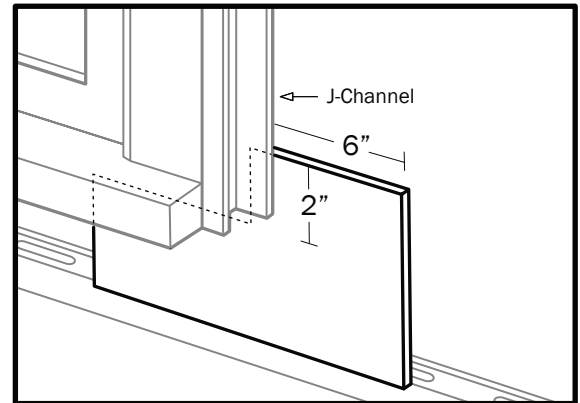

Figure 13.1

## Inside Corners

Two J-channels at right angles may be used for the inside corners (**Figure 13.2**). Install a small bead of caulking where the two J-channels meet one another (**Figure 13.3**). J-channels should be installed at full lengths, 1/2" below the bottom of the starter strip and extending to the eave line or gable trim. If a shorter piece is needed to reach the eave or gable trim be sure to overlap the bottom piece with the top piece. J-channel flanges should be nailed every 12", making sure not to drive the nails too tight. Driving nails too tight may cause a distortion to occur in the J-channel. J-channels can easily be cut with a pair of aviation snips.

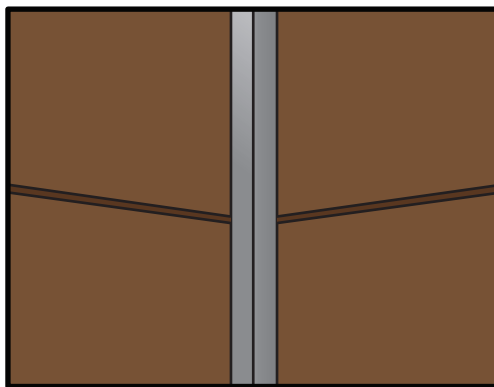

Figure 13.2

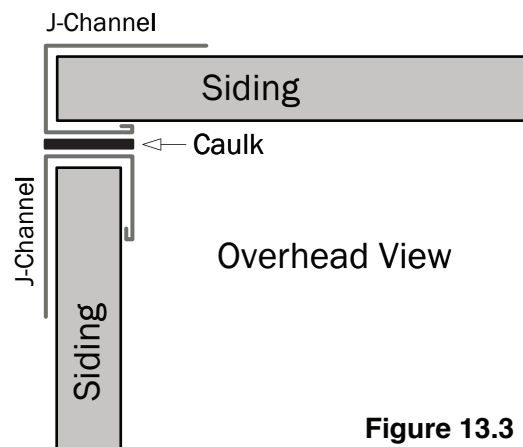

Figure 13.3

## Expansion for Inside Corners

Siding is installed into the receiving end of the J-channel. Make sure to leave 1/16" of space between the back side of the J-channel and siding.

# Accessory Installation

## Bold Window and Door Trim

The bold window and door trim is installed after all your siding is completed. The 1 inch leg of this trim piece will slide tightly between the J-channel you butted against the window frame and the window frame itself for a tight, friction hold. This of course is done after you measure your pieces and 45 your corners. For more info on this, reference our installation video online.

[www.youtube.com/watch?v=7ENHONRlqrw](http://www.youtube.com/watch?v=7ENHONRlqrw)

## Two Piece O.C.P. Installation

The Two Piece O.C.P. base is installed first, before the cap is attached. Fasten the base to the building plumb to the corner,  $\frac{1}{2}$ " below the bottom of the starter strip. This can be done with a plumb line as a level. If more than one post is needed to reach the desired height be sure to overlap the bottom corner with the top corner. Be sure to install nails every 12" on both nailing areas. Do not over tighten screws or drive nails too deep to avoid distortion. Make sure the corner base is installed squarely to the wall, this will add to the final appearance of the job. Once the base is installed, cut your siding to fit tightly into the pocket and then add the cap to finish it off. Attach one side of the cap to the base along the full length, and then work the other side in. No nails are needed to install the cap (Figure 14.1).

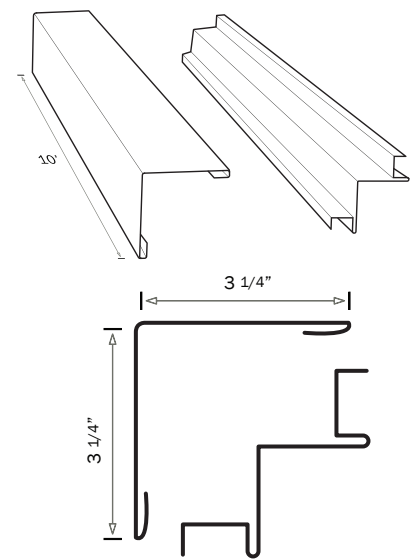

Figure 14.1

## J Block Installation

Utility J-block Installation Video (Starts at 7:35)

[www.youtube.com/watch?v=0KzYbWhjE3g](http://www.youtube.com/watch?v=0KzYbWhjE3g)

Light J-block Installation is identical to the Utility J-Block method.

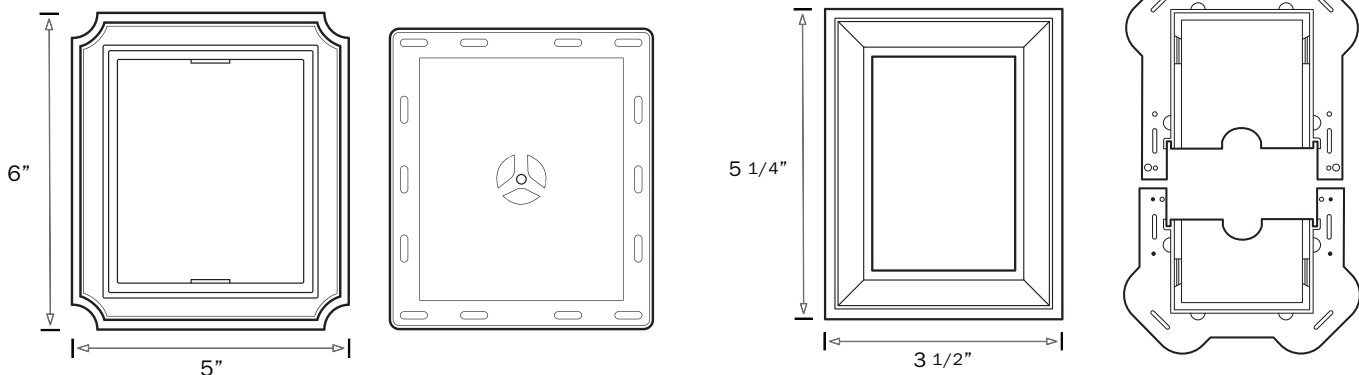

# Siding Termination Methods

## Siding Termination Methods

Depending on your project and soffit material, there are 3 different termination methods for our steel log siding.

### Installation Video - Option 1

[www.youtube.com/watch?v=jcgcNkxy72s](http://www.youtube.com/watch?v=jcgcNkxy72s)

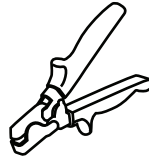

### Snap Lock Punch/Notching Tool

We recommend:

- Malco SL-1 Snap Lock Punch

**Option 1 :** If you have a vinyl or metal soffit, you can use our frieze board/crown. You won't install this until you've run the siding all the way up to the soffit. You will need to notch out this trim piece and snap it into the soffit J-channel/F-channel between the soffit panel and the existing soffit J-channel.

### Installation Video - Option 2

[www.youtube.com/watch?v=GIkuiVEKfGc](http://www.youtube.com/watch?v=GIkuiVEKfGc)

**Option 2 :** If you have an open rafter soffit or angled soffit, you can terminate the siding with a J-channel and sill trim. Before you start siding, run your J-channel all the way around your house, including the gable ends. This is where the wall and soffit come together. It is not necessary to leave any space above the J-channel where the soffit starts.

- The sill trim would only be installed on the long runs of your house where you have cut off the nail strip. After the sill trim is installed over the cut edge of the panel, you will slide the sill trim and panel into the previously installed J-channel and face nail or screw the last panel.

### Installation Video - Option 3

[www.youtube.com/watch?v=Wh4\\_gWeDJgY](http://www.youtube.com/watch?v=Wh4_gWeDJgY)

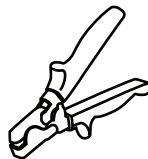

### Snap Lock Punch/Notching Tool

We recommend:

- Malco SL-1 Snap Lock Punch

**Option 3 :** If you have a flat wood or composite soffit, you can terminate into our crown keeper and crown. This is the preferred method if you don't have a metal or vinyl soffit. Before you start the siding, run the keeper all the way around your house, including the gable ends. This is where the wall and soffit come together. The keeper trim piece takes the place of your soffit J-channel/F-channel if you were to have a metal or vinyl soffit. The keeper piece should be touching the existing soffit. You won't install this until you have run the siding all the way up to the soffit. You will need to notch out this trim piece and snap it into the soffit J-channel/F-channel.

# Steel Siding Cutting

## Power Saw

Steel siding may be cut with a carbide tip saw blade that is specifically designed for cutting steel. You can use a ferrous or non-ferrous metal cutting blade. The more teeth on the blade the better for a cleaner cut. For the lap siding, start your cut at the top lock/nail flange. Get your blade started in there and pull the miter saw towards you nice and smoothly.

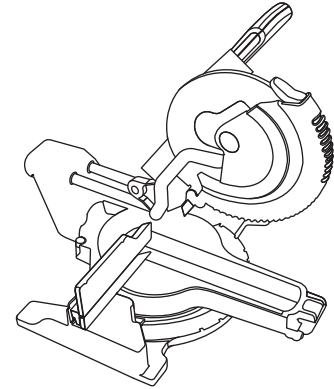

## Tin Snips

Tin snips may be used to cut siding (**Figure 16.1**). Start by drawing a straight line on the siding with a speed square. Then start cutting from the lock edge first working downward through middle butt carefully, Continue downward, snipping through and around the bottom lock. Then use a screwdriver to re-open the lock edge and bottom locking edge. Tin snips are also used to cut J-channels, finish trim, and O.C.P.

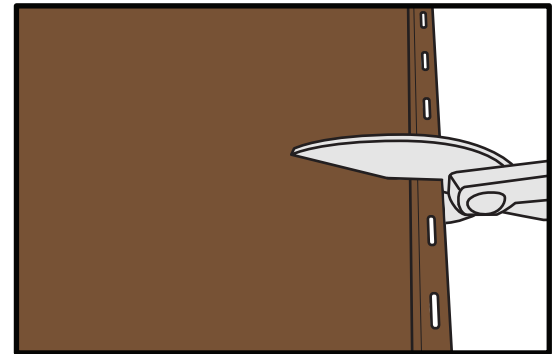

Figure 16.1

## Electric Shear

This tool may be used for length wise cuts across face of siding. Especially helpful for window and door cuts (**Figure 16.2**).

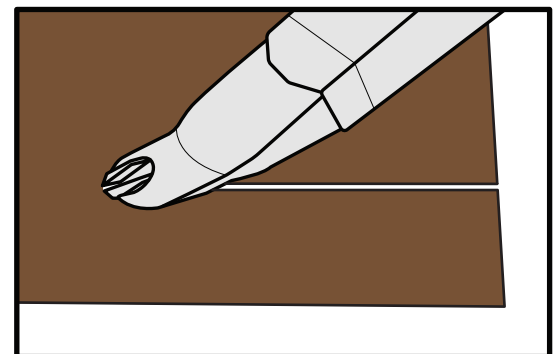

Figure 16.2

# Panel Installation

## Row One

Row one is the most important row of siding on the building. This row is the basis for all other rows of siding to be installed. Make sure this row runs parallel to the eaves and or windows, or is level depending on the situation (**Figure 17.1**). Install the bottom lock of siding around bottom edge of the starter strip, be sure that entire bottom lock of siding is around the bottom of the starter. Be sure not to pull too hard on this row when screwing or nailing. If forced too hard a distortion of the panel may occur. Check for alignment of the inside and outside corners making sure panel matches up at all corners.

You should have a minimum of 6" of clearance between the ground and the bottom of the first row. Install the end of the siding into the corner post openings first, then apply upward pressure down the entire piece of siding while making sure the lock on the siding goes around the steel starter strip. Screws or nails should be spaced 16" O.C. in the middle of the factory screw or nail slots provided at the top of the siding panel (in studs where possible). If using a smooth shank nail make sure it is driven in a minimum of 3/4" into solid lumber.

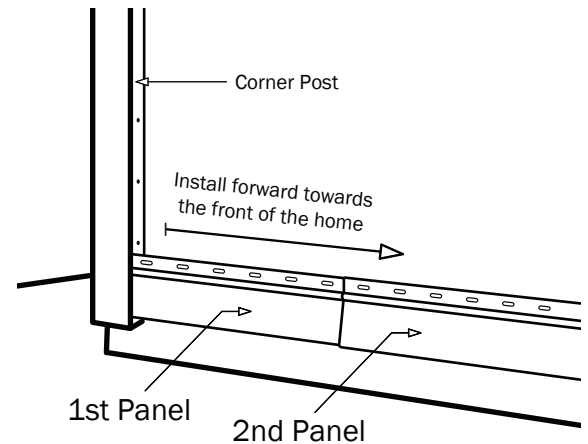
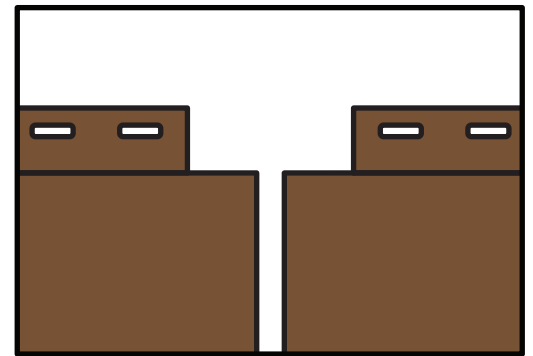

**Figure 17.1**

## Panel Laps

Be smart in how you lap your siding. On the sides of the building start at the rear of the side and work towards the front, this will make your laps less noticeable from the front of the building. Always start away from driveways or doors and work towards them, this will allow for the laps to be less noticeable.

Always lap the factory cut over the field cut. Using these techniques will allow for a better finished product. Siding should overlap each other by approximately 1/4" to 3/8". You do not need to allow for much expansion or contraction since this is a metal product. (**Figure 17.2**).

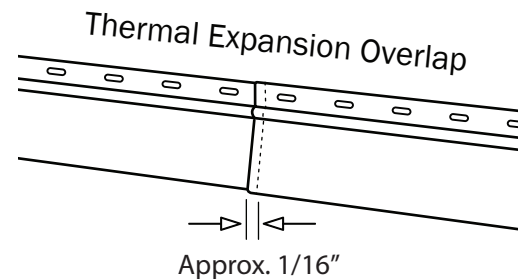

**Figure 17.2**

## Expansion and Contraction

Steel siding will expand and contract minimally when heated and cooled. The normal expansion and contraction rate is 1/16" per 12' panel over a 30° F temperature change (**Figure 17.3**). Using this guide will help you achieve a great appearance of your new siding, and also avoid any waves or buckling that may occur if the siding is installed too tightly.

When installing into wood or PVC trim the siding may be tight. The soft trim material will absorb the 1/16" expansion that may occur.



**Figure 17.3**

# Panel Installation

## Proper Siding Staggering

Thought and care should be used when staggering joints of siding. A minimum of 2' distance between overlaps of siding and also a bare minimum of two rows of siding between joints that are in line vertically. Following these guidelines will improve the overall appearance of the siding job.

Stair stepping or aligning the joints of the siding vertically will attract the eye to all of the overlaps, and detract from the new siding. A good rule of thumb is to place your overlaps on a random pattern (**Figure 17.4**).

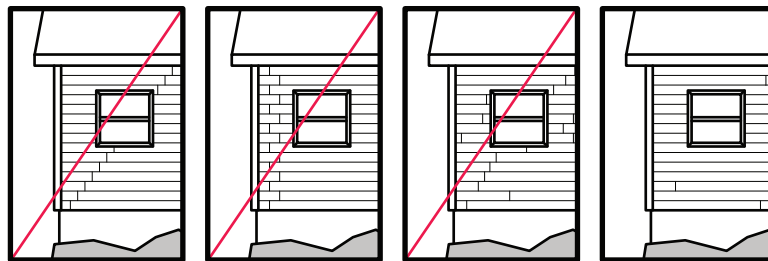

Wrong

Wrong

Wrong

Correct!

**Figure 17.4**

## Hanging of Siding

When placing screws or nails through the factory slots be sure to place your screw or nail in the center of the factory slot (**Figure 18.1**). Screw or drive a nail into the flange while taking precaution not to drive in too tight. By doing this you will allow the siding to expand and contract freely with the temperature changes and eliminate any waving or buckling.

The steel siding does not need to be nailed tight to the sheathing if the wall has a wave in it. This will help “flatten out” the surface of the exterior of the building.

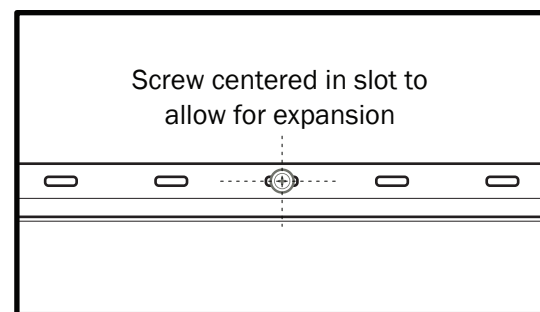
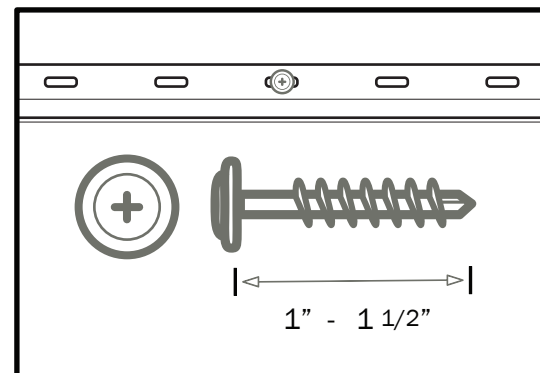

**Figure 18.1**

## Screws

Be sure to use a proper flathead screw when installing the siding. Drive screws straight in, don't angle the screws up or down. Screws driven in at angles may cause the siding to buckle. Be sure to use the proper length screw, a good standard is a 1" to 1 1/2" flathead screw (**Figure 18.2**). The screw should be driven into a minimum of 3/4" of solid wood. Try to hit studs if possible whenever placing a screw where it is visible be sure to use a trim nail the same color as the siding or accessory you are screwing into. Screws should be placed a maximum of 12" O.C.

Do not place screws closer than 8" from siding overlaps. If a bow in the wall is present place a screw on each side and span the bow. This will keep your siding from having a wavy appearance. If placing siding over any existing wood siding be sure any rotten or damaged wood is replaced prior to installation and that it is as even or straight as possible.



**Figure 18.2**

## Power Nailers

**Power Nailers may be used, if you follow the same techniques as above.**

Be sure to adjust the pressure so you do not drive the fasteners in too tight.

# Panel Installation

## Panels at Window (Bottoms)

When installing siding under windows and doors, most likely you will have to cut the siding to fit under the window (**Figure 18.3**). Be sure to plan your row of siding so that you will have a screw in a flange on each side of the window. Hold the piece of siding in place taking caution on overlaps. Mark the top of the siding where it will need to be cut so it will slide into the J-channels on the sides of the window. Next hook your tape measure on the bottom of the lock of siding directly under the window, measure to within a 1/4" of the sill. Finally transfer these measurements to the siding panel, making sure you measure from the bottom of the siding panel.

**\*Note:** Be sure to measure both sides of the window, you may find some openings are not always level.

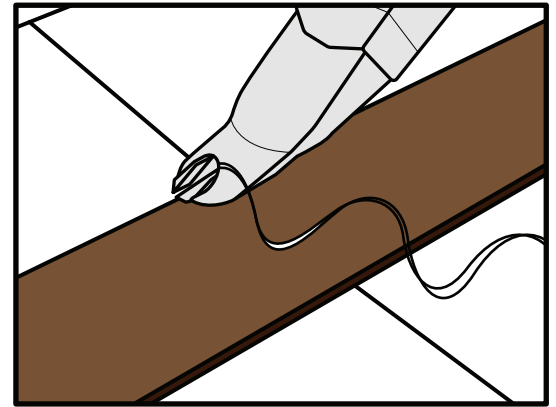

Figure 18.3

## Panels at Windows and Doors (Tops)

Cutting out the tops of windows and doors is nearly the same as the bottoms. The difference in this process is the clearance needed to install the siding. When measuring your clearance, measure tight to the inside of the J-channel. When cutting horizontally, cut an extra 1/4" to allow for the bottom of this panel to slide over the lock of the lower panel and engage it.

## Gable End Measuring and Cutting

Angle cuts will have to be made on siding in gable sidewalls. A pattern can easily be made for these angles. Start with two small pieces of siding, lock one piece onto the panel below the start of the gable. Slide the second piece into the eave and then draw a line on the second piece using the first piece as a guide. (**Figure 20.1**). Cut on this line with a power saw or tin snips.

You now have a pattern to transfer your cut lines on each row of siding in the gable (**Figure 20.2**). Be sure to check your pattern often, all gable slopes are not always straight. Any roof slope can be handled in this manner.

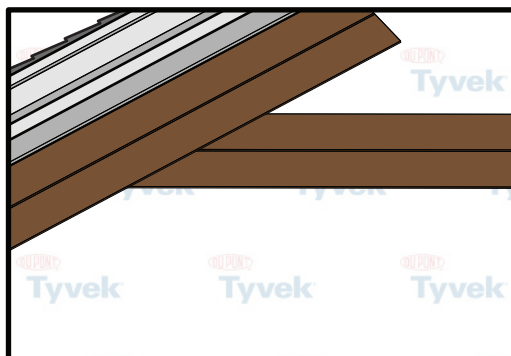

Figure 20.1

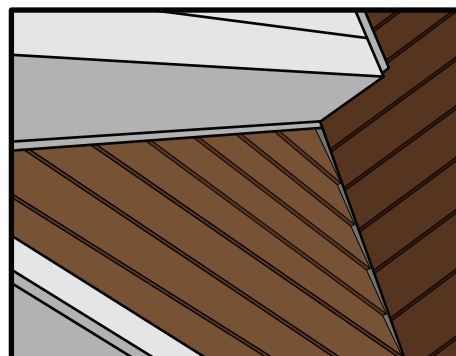

Figure 20.2

# Panel Installation

## Installing

Install the angled end of the siding into the J-channel first then lock the butt end of the siding into the lower row of siding. Make sure you maintain the proper allowance for expansion and contraction. The final row of the peak may be nailed with a trim screw or nail that matches the siding color through the face of the siding. Touch-up paint can be used to cover any exposed screw or nail heads.

## Subsequent Rows

For your second piece of steel siding on the same row you just started take out the foam backer from the panel to make it easier for installation. You will notice a notch out at the top and bottom of the panel. This allows the panels to overlap each other about a  $\frac{1}{4}$ " to  $\frac{3}{8}$ ". The seams will lay flat with each other and you will be able to drop in the foam backer and secure the panel to the wall.

## Final Row of Siding Under Eaves

The last row of siding will most likely have to be cut down to fit under the eave (**Figure 20.3**). To do this measure from the lower row's lock to the bottom of the eave.

Transfer this measurement to the panel to be cut. Use an electric shear to make this cut  $\frac{1}{4}$ " below the line. Check to see if furring is needed to keep slope angle correct. If needed install furring. Install finish trim flush with the eave. Finish trim should be installed on the entire length of the wall.

The siding can then be inserted into the finish trim and locked into the lower row of siding. This row may be held in place by applying a bead of caulk in the lock of this panel prior to installation. Trim screws may be needed in the weep holes to keep siding in place, be sure to use touch-up paint to cover exposed screw heads.

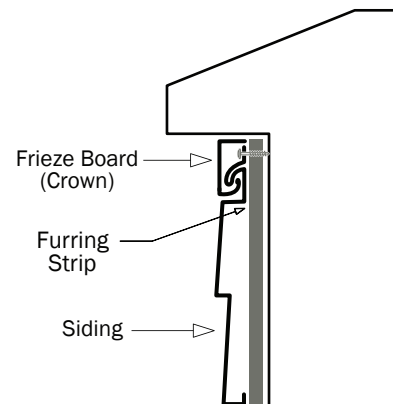

**Figure 20.3**

## Replacing Damaged Panels

Cut damaged panel just above the center with an electric shear. Remove the bottom section of damaged panel. Do not remove remaining siding panel.

Remove the top lock of the replacement panel as high under the lock as possible. Remove any burrs or imperfections that may have occurred while cutting. Slip the new piece of siding under the old lock. If this lock is too tight, open the gap with a flat screwdriver.

Apply adhesive caulk on the full length of the old panel  $\frac{1}{2}$ " to  $\frac{3}{4}$ " under the old lock.

Install the new piece of siding carefully over the top of the adhesive caulk and into the old lock. Press the new panel into the caulk so that it makes contact the full width of the siding. Do not nail this panel into place. Use this procedure for all replacements. Screw or Nail through the weep hole with stainless steel trim screws or nails to hold the panel in place.

# Panel Installation

## Clean-Up

Use a mild soap and water for clean-up with a soft cloth or sponge. Do not rub excessively, this could cause damage to the surface. Do not use harsh abrasives. Mineral spirits may be used sparingly to remove grease or asphalt stains.

## Job Site

Re-install all fixtures and wires that were removed prior to installation. Scrap pieces, siding boxes, nails, debris, etc. should be removed daily.

## Additional Tips

It may be necessary to leave J-channels or corner posts loose around openings to help for installation of short siding panels. You may also have to leave J-channels off to get short pieces in and slip a J-channel in after installation. Nailing for this procedure can be done into the back side of the J-channel at every other row into the casing which it is butted into. A nail set will help in this procedure to set your nails into the wood. If leaving J-channels loose bow out ends and slip siding into J-channels and lock together.

# TruLog™

MAINTENANCE-FREE STEEL SIDING

20684 Niobrara Blvd. • LaSalle, CO 80645

---

**970-646-4490**

---

info@trulogsiding.com • www.TruLogSiding.com



facebook



instagram



pinterest



houzz



Patented Profile and  
Registered Trademark