

TruLog™

MAINTENANCE-FREE STEEL SIDING

BOARD & BATTEN SIDING INSTALLATION GUIDE



970-646-4490
www.TruLogSiding.com



USA Made Steel
Manufactured in the USA

Table of Contents

Siding Profile	3	Steel Siding Cutting	15
Accessories	4	Siding Termination Methods	16
Tools & Equipment	7	Panel Installation	17
Cutting Tools	8	Starting Your Siding	17
Fasteners	9	Corner Caps	18
Preparation	10	Hanging of Siding	18
House Insulation and House Wrap	10	Locking Sliding Panels	18
Surface Preparation (If Needed)	10	Panels at Windows and Doors	19
Window Sill Preparation (If Needed)	10	Bold Band Board Installation	20
Straitline	11	Inside and Outside Corner Panels	20
Level	11	Clean Up	21
		Job Site	21
		Additional Tips	21
Accessory Installation	12		
Rat Stop / Starter	12		
Window and Door J-Channel	12		
Flashing	12		
Inside Corners	13		
Expansion for Inside Corners	13		
Bold Window and Door Trim	13		
Two Piece O.C.P. Installation	14		
J-Block Installation	14		

Board & Batten Siding Profile

9.25" Board & Batten Siding Profile

Our Board & Batten siding covers 9¼" wide on the wall and the panels are 8', 9', and 10' standard lengths as well as up to 16' using custom lengths. Our metal Board & Batten product offers the look of a rustic home while providing maximum durability and easy upkeep. Board & Batten Siding by TruLog has a genuine wood appearance but requires no care other than an occasional rinse with the garden hose.

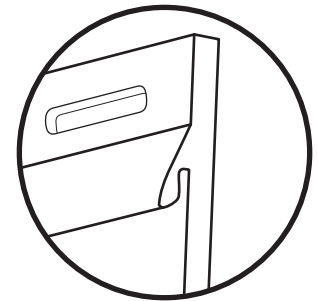
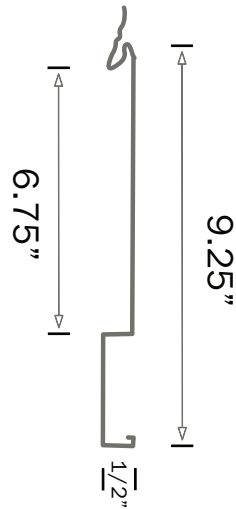
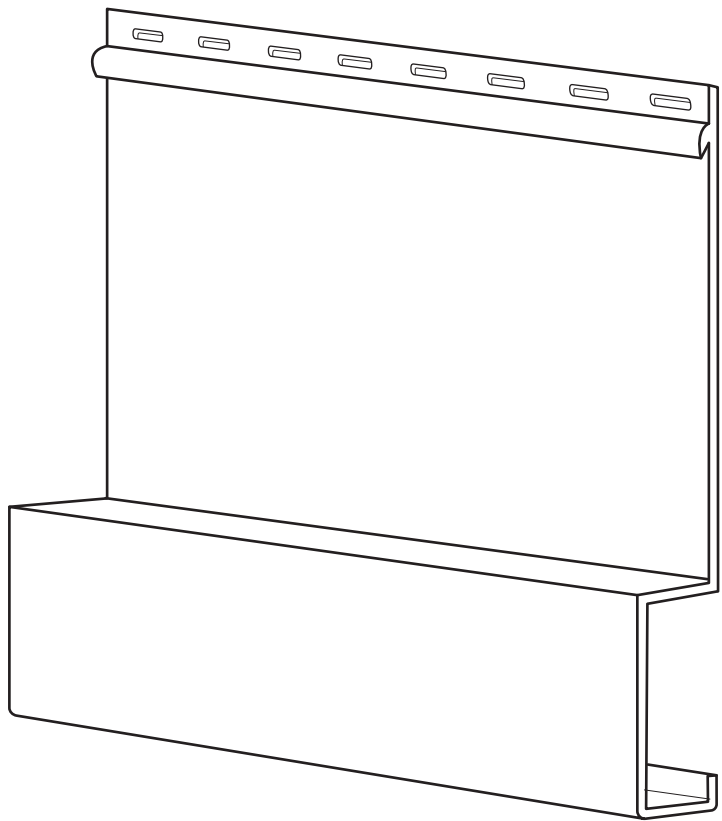

Nail Strip
& Top Lock

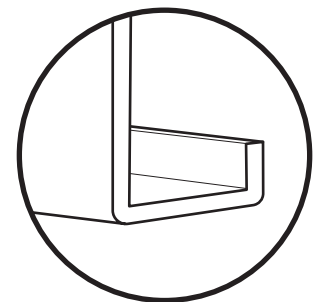

Bottom Lock

Board & Batten Color Matched Accessories

J-Channel

The J-Channel is used in various places but is mostly used to trim around doors and windows to accept siding in those areas. You can also use the J-Channel to terminate our siding at the soffit level, use it for inside corners by butting two J-Channels together, on top of decks or patios where there is an elevation change, on a roof line, and numerous other places. The J-channel is used to hide cut edges of the siding and is nailed or screwed 12 inches on center.

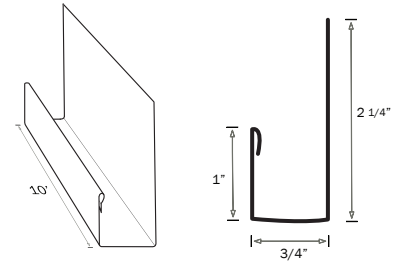

Bold Band Board

The band board is used to transition one section of the board and batten on top of another. If you have a wall taller than 10 ft, the band board is used to cap the lower section and also act as the starting point for the next section above it.

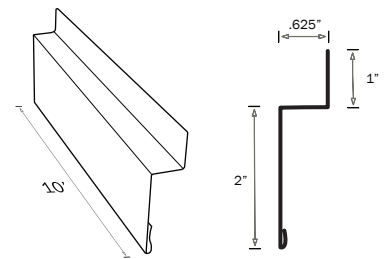

Sill Trim

Sill is used to cover the cut edges of steel when you cut your panel down to fit around your doors and windows.

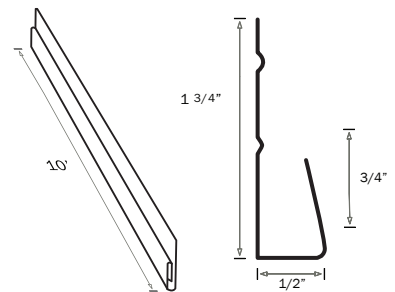

Rat Stop / Starter

The starting point for your installation – installed at the bottom of the wall just like other starter material, and prevents any rodents from getting behind the siding.

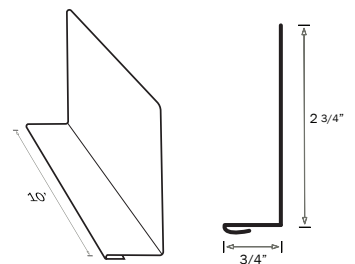

Corner Base & Cap

Corner bases and caps are used to cover up the corners of your house and hide the cut metal siding. A corner base is applied to the home so the corner cap can be snapped on over the top. Corners provide your home with a great finished look as well as protects the end of your TruLog™ siding.

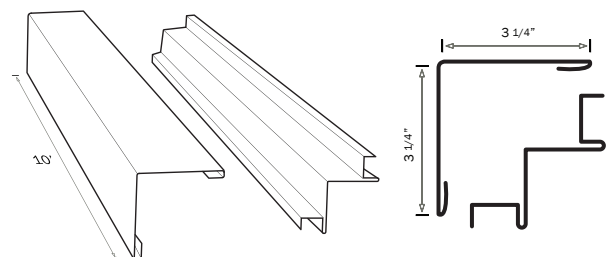

Board & Batten Matched Accessories

Bold Window & Door Trim

Bold window and door trim is an optional trim piece that gives your doors and windows a bold and finished look. This trim piece is installed after all of your siding is up and you are ready to finish the installation. You will still need to use a j-channel around your doors and windows and then slide this trim piece in between the window frame and the j-channel for a tight, friction hold. You can also run a bead of caulking on the inside leg of the bold trim, before installing it in between the j-channel and window frame, for extra holding strength. Once in place, use a bead of caulking where the bold window trim and window frame meet for increased holding strength.

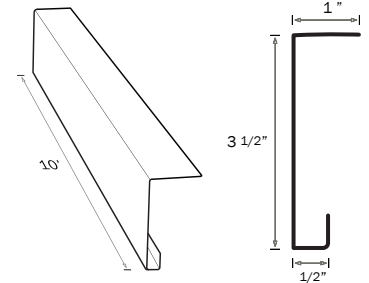

Custom Trim

If you have a specific trim piece in mind that is not listed in this guide, we can bend one for you if you provide the dimensions of the piece.

Trim Coil

If you are wanting to bend your own custom trim pieces on the job site, we can provide you with color matched steel coil. Keep in mind our steel is 26 gauge and will take a mini 5 clamps on your sheet metal brake in order to bend it.

Utility J-Block/Split Mini

Utility J-blocks are used to trim around your outlets or spigots. The back of the J-block can be cut to fit either of these profiles. You fit the exterior penetration, install siding around it and snap the beauty ring over the top. It is a 2-piece system making siding around these areas much more simple.

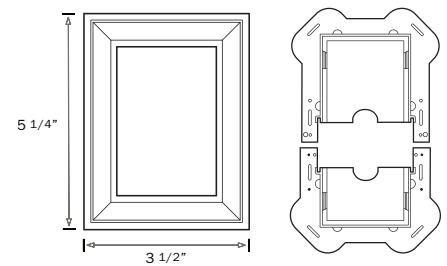

Light J-Block

Light J-blocks are used to mount your lights to using a simple base and cap system. First you attach the base, then pull the wires through, then install siding around it, and snap the beauty ring on. Finish by mounting your light over the top of the raised base.

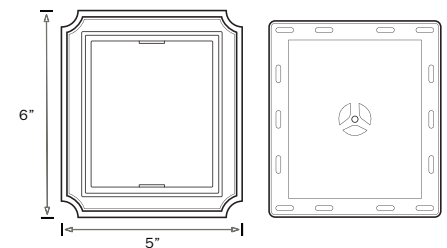

Board & Batten Color Matched Accessories

Dryer Vent

The dryer vent is another j-block that helps simplify siding install. The Dryer Vent comes with a metal 4" tube that slides into the house, siding is installed around it, and then a beauty ring is snapped on over the top.

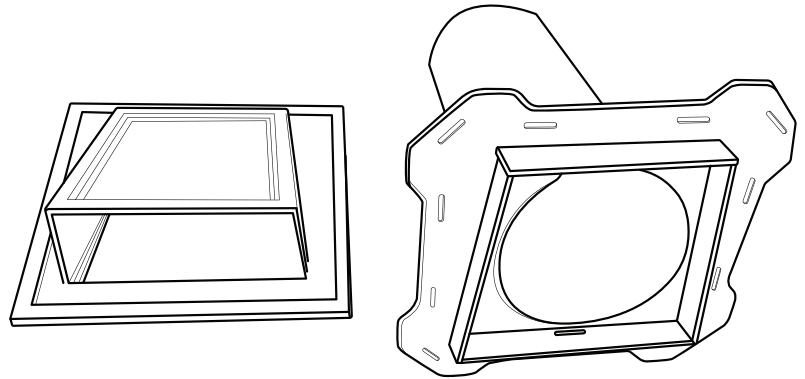

Exhaust Vent

Exhaust vents are used for bathroom fans, furnace fans, and other applications. The Exhaust Vent comes with a metal 4" tube that slides into the house, siding is installed around it, and then a beauty ring is snapped on over the top. Exhaust Vent is identical to the Dryer Vent but has flaps instead of a hood for the opening.

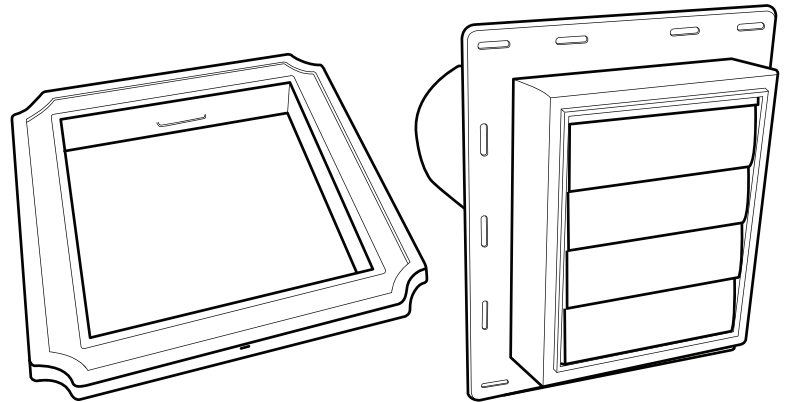

Jumbo J-Block

Jumbo J-blocks are used to mount your lights to using a simple base and cap system. First you attach the base, then pull the wires through, then install siding around it, and snap the beauty ring on. Finish by mounting your light over the top of the raised base.

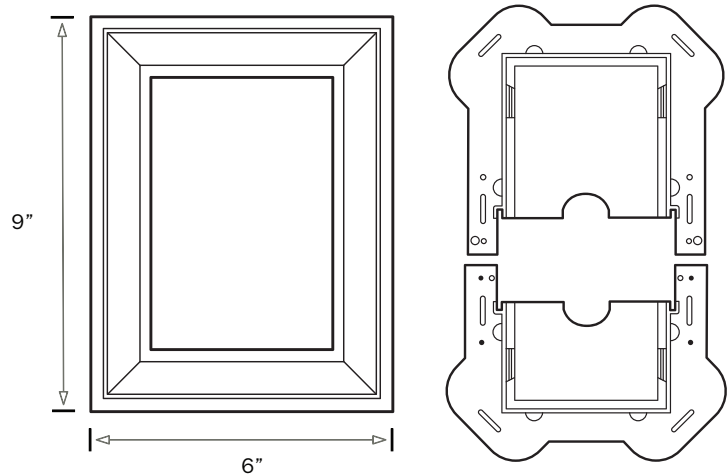

Tools and Equipment

Tools

Helpful Tools for Installation

- Hammer
- Level
- Tape Measure
- Power Saw (with steel sheet metal blade)
- Electric Shears
- Utility Knife
- Drill
- Prybar
- Safety Goggles
- Aviation Snip
- Flathead Screwdriver
- Caulk Gun
- Speed Square
- Needle Nose Pliers

Additional Tools for Installation

- Trim Coil
- Touch-up Paint
- 1" - 1 1/2" Galvanized Fine Thread Screws or Nails
- 1" to 1 3/4" Steel Trim Nails
- Nail Punch
- Butyl or Urethane based caulk

Equipment

Siding Cutting Table

This table allows for a normal circular saw to be used with the proper steel blade to cut siding and soffits. It is especially helpful for angled cuts on peaks and rakes. These tables are lightweight, portable, and can be set up and moved by one person with ease. These tables also allow for the saw to be away from the siding when being cut, which allows for fewer scratches or damage to occur to the siding panels.

***Always make sure to wear protective safety glasses and gloves when cutting/handling steel siding.**

***Follow safety instructions that accompany your tools/blades and wear the suggested protective gear.**

Cutting Tools

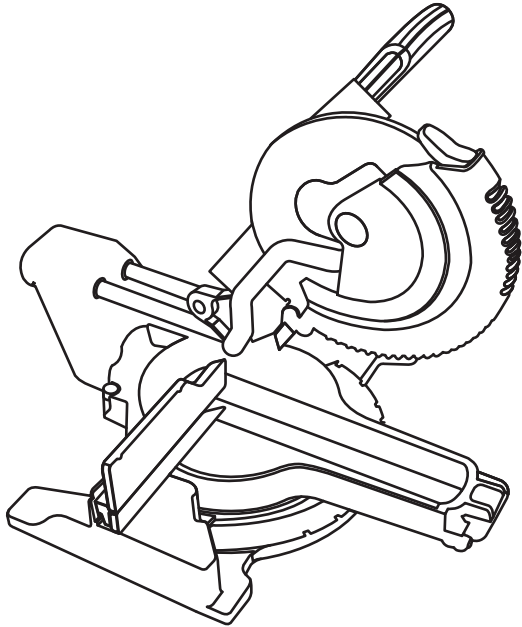

Sliding Miter Saw with Ferrous Metal Cutting Blade

We recommend brands such as:

- Diablo
- Tenryu
- Irwin

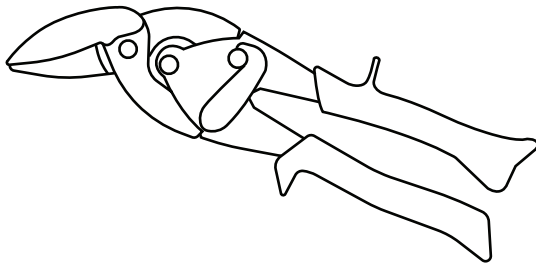

Steel Snips or Hand Snips

We recommend Midwest Left & Right
Offset Aviation Snips.

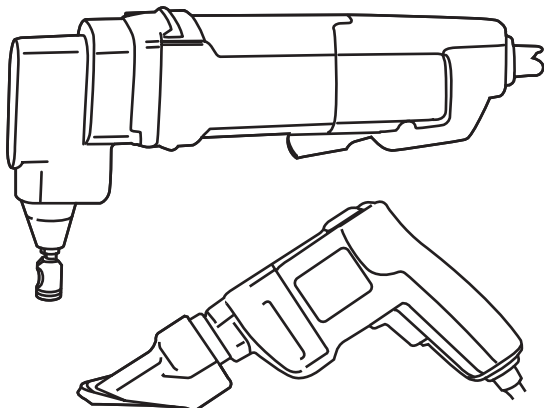

Nibblers or Electric Shears Stand Alone Tool or Drill Attachment

We recommend brands such as:

- Dewalt

Fasteners

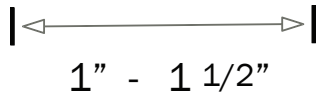
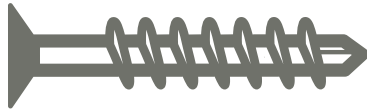

Galvanized or Anodized Screw

A screw with fine threads from 1" - 1 1/2" inches in length.

We recommend:

- Grabber Fasteners
- Bugle Head Phillips Gold Screw
- Comparable screw with similar length and profile to the above.

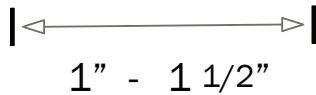
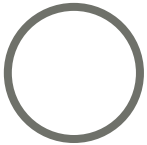

Carpenter Nails

Any Carpenter nail will work fine.

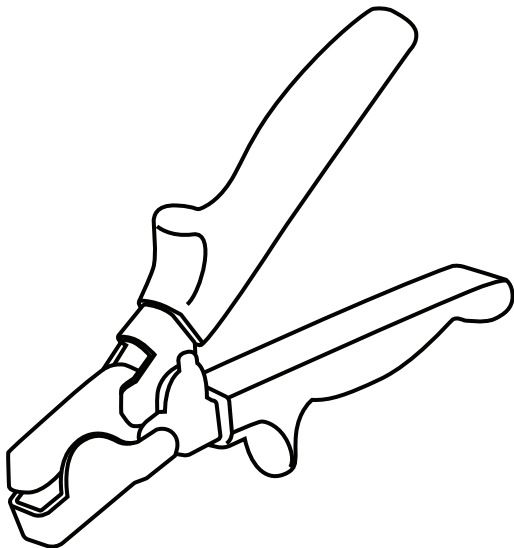

Snap Lock Punch/Notching Tool

You will need a notching tool if you order our crown/frieze board termination tool. This tool is used to punch a notch in the leg of the crown so you can snap it into a soffit J-channel made out of either metal or vinyl.

*Used only if you purchased our frieze board/crown trim piece.

We recommend:

- Malco SL-1 Snap Lock Punch

Preparation

TruLog steel lap siding needs to be installed on a flat wall surface in order for the panels to interlock and overlap correctly. If you do not have a flat wall surface, you will need to create one by furring out the wall with foam, OSB board, or furring strips, whichever makes the most sense to you. Make sure to level out the wall as best you can before starting the siding.

House Insulation and House Wrap

For the typical siding application house wrap or sheet insulation can be placed on the exterior of the wall right over the OSB or plywood. House wrap will prevent drafts from occurring and will also shed any moisture that may get behind the siding. We recommend Tyvek brand house wrap since it is woven more tightly than other brands. If insulation is needed this should be installed over the OSB/Plywood and under the house wrap. **(Figure 10.1)**

Surface Preparation (If Needed)

Remove and replace any rotted or damaged boards. Check for waves in the wall and shim out (or build out) if necessary. Nail or screw down any loose boards or trim. Scrape away any old caulking, especially where it may interfere with the new trim pieces (windows and doors). New caulking should be installed to seal any air leaks where old caulk was removed. Remove or loosen objects that may be in the way of the new siding (downspouts, cables, planters, shutters, house numbers, mailboxes etc.). If meter boxes or power lines must be removed contact a local professional. Best practice is to remove the old siding before installing TruLog™ Steel Siding.

Window Sill Preparation (If Needed)

Window sills may be cut off flush with the vertical window casing to allow the J-Channel to be installed flush with the casing. Coil stock can then be installed around the window casing and sills using a brake. Flashing may be prepared under the window to keep water from getting behind the siding. If you are installing siding on a new structure with new windows, butt your J-Channel tight to the window frame and follow the J-Channel instructions. If you are installing bold window and door trim in addition to the J-Channel, follow those instructions as well in. **(Figure 10.2)**

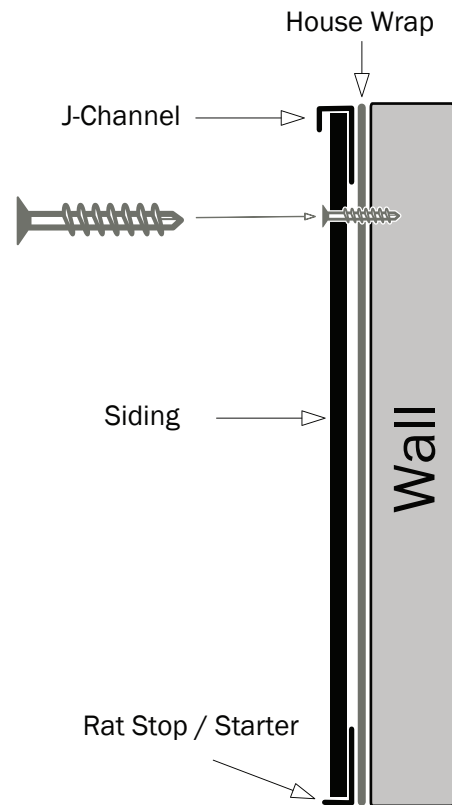

Figure 10.1

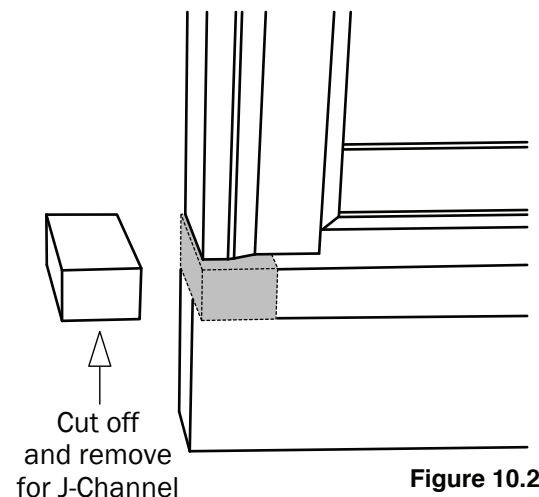

Figure 10.2

Preparation

Straightline

A chalk line is a good way to start an installation. Often times this is used to develop a reference line as to which the starter strip can be installed. We recommend measuring equal distances down from the eave line, or from the window sills that are at the same height (**Figure 11.1**). This line allows for the siding to be run parallel with the eaves or windows which gives the appearance that the siding is running level regardless of the actual levelness of the house or ground.

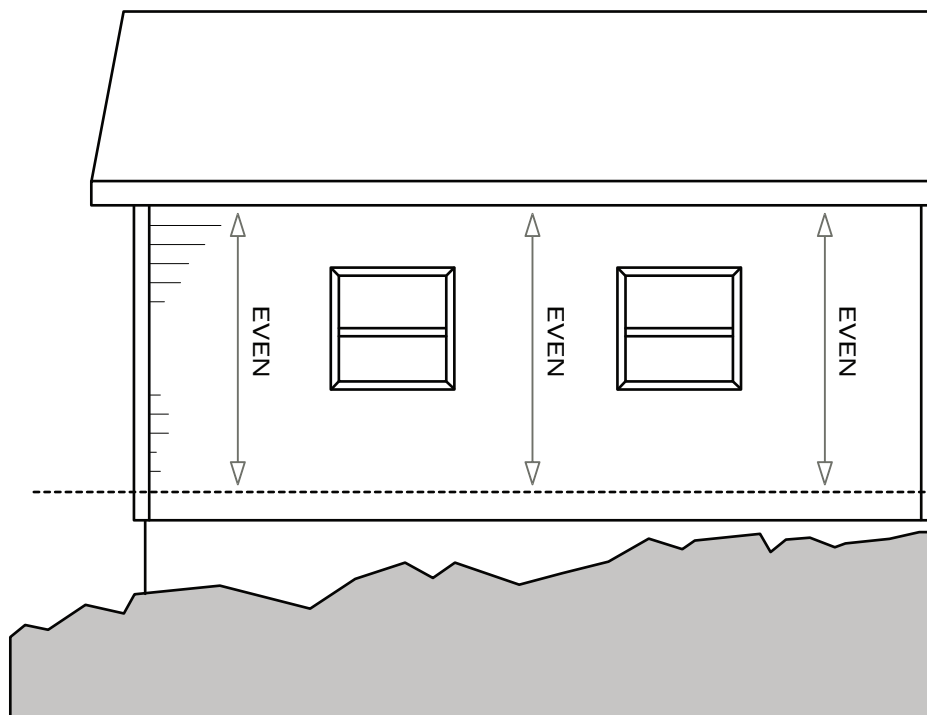

Figure 11.1

Level

Another good way to start an installation is to check if the walls are level. If the walls are reasonably level a chalk line and level may be used to determine a line for the starter strip to be installed. This is done by driving a screw at the desired height for the top of the starter strip. Then connect the end of the chalk line to the nail and pull it to the opposite end of the wall, making sure to pull the line tight. Then use a level in the middle of the line to determine where the chalk line should be snapped. Be sure there is no sag in the line when it is snapped, this can easily occur when the line is stretched over 20'. Continue this process on all sides of the building making sure the line matches up on all sides. This is very important as this is the basis for all subsequent rows of siding.

***It is recommended to use a level 4' or longer in this process and also to take level readings at the center of the line.**

Accessory Installation

Rat Stop/Starter Installation

Your Rat Stop/Starter is the starting point for all of our vertical board & batten siding. This piece will lay on top of where you have your level line set and you will set the panel right on top of the L-angle portion of the rat stop. as the starting point for your siding. Overlap the pieces a little bit, this will reduce any air leaks. Be sure to screw the rat stop/starter each 12" on center. **(Figure 12.1)**

Do not overdrive screws to prevent distorting the trim piece.

Rat stop can be cut with tin snips if you need shorter lengths.

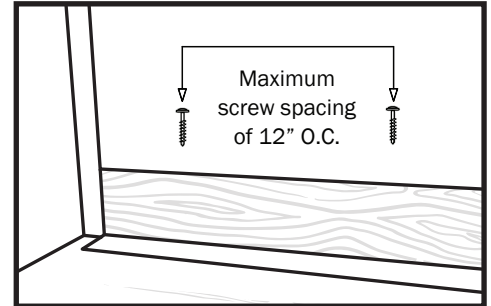

Figure 12.1

Window and Door J-Channel Use

J-channels need to be installed around windows and doors **(Figure 12.2)**. This is done so the butt end of the siding can be slipped into the J-Channel opening. The side pieces of J-Channels are left $\frac{3}{4}$ " above the window top, and $\frac{3}{4}$ " below the window sill. The bottom of the J-Channel has a V-groove notched out of the back side and nail flanges ($\frac{3}{4}$ " depth). This allows for the siding to slip into the finish trim and hide the cut of the finish trim.

The top of the J-Channel has the back side notched out $\frac{3}{4}$ ", leaving the face and nail flange in place. The top J-channel is cut to fit from outside to outside of the side J-channels. A $\frac{3}{4}$ " slit is cut into the corners of the J-Channel and top is folded down inside the side J-channel pocket. Be sure to put the face of top J-Channel over the face of the side J-Channel. Drip caps need to be installed before the J-channel at the top of the windows and doors. L-Channels should be used in this application.

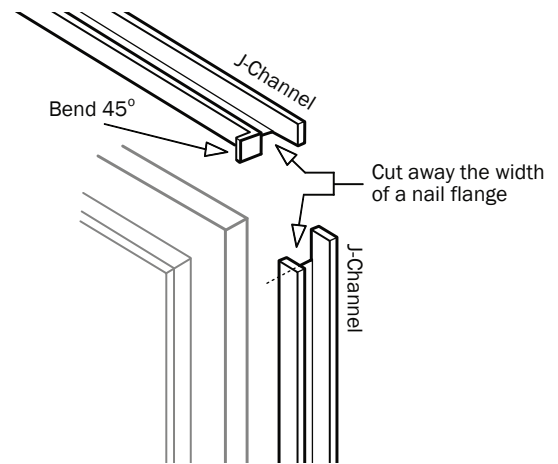

Figure 12.2

Flashing

It is a good idea to install window tape over existing window nail flanges **(Figure 12.3)**. Also you may install a piece of window tape or coil stock under the nail flange of the side J-Channels and lap over the nail flange of the siding panel directly under the window or opening. This will allow water to run over the top of the siding and out the weep holes in the bottom of the siding instead of behind the siding panel.

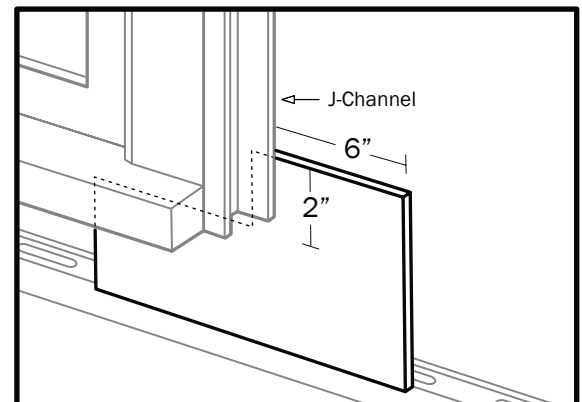

Figure 12.3

Accessory Installation

Inside Corners

Two J-channels at right angles may be used for the inside corners (**Figure 13.1**). Install a small bead of caulking where the two J-channels meet one another (**Figure 13.2**). J-channels should be installed at full lengths, $\frac{1}{2}$ " below the bottom of the starter strip and extending to the eave line or gable trim. If a shorter piece is needed to reach the eave or gable trim be sure to overlap the bottom piece with the top piece. J-channel flanges should be nailed every 12", making sure not to drive the nails too tight. Driving nails too tight may cause a distortion to occur in the J-channel. J-channels can easily be cut with a pair of aviation snips.

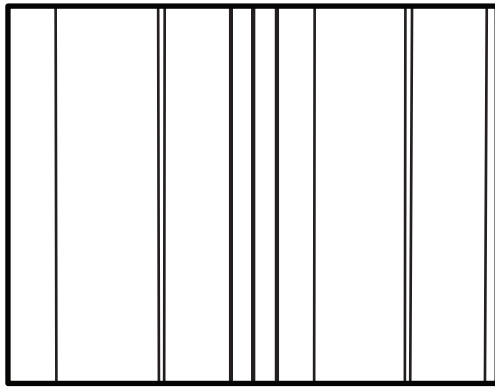

Figure 13.1

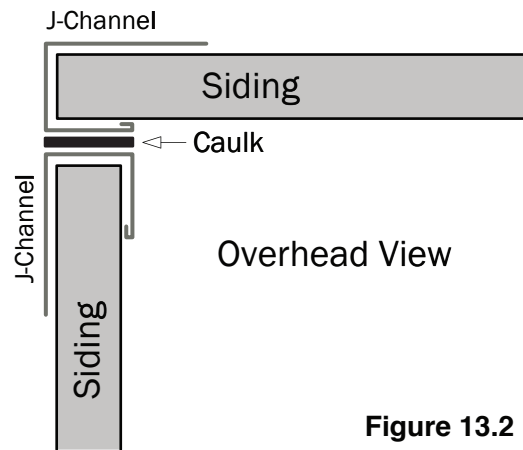

Figure 13.2

Expansion for Inside Corners

Siding is installed into the receiving end of the J-channel. Make sure to leave $\frac{1}{16}$ " of space between the back side of the J-channel and siding.

Bold Window and Door Trim

The bold window and door trim is installed after all your siding is completed. The 1" leg of this trim piece will slide tightly between the J-channel you butted against the window frame and the window frame itself for a tight, friction hold. This of course is done after you measure your pieces and 45 your corners. For more info on this, reference our installation video online.

www.youtube.com/watch?v=7ENHONRlqrw

Accessory Installation

Two Piece O.C.P. Installation

The Two Piece O.C.P. base is installed first, before the cap is attached. Fasten the base to the building plumb to the corner, $\frac{1}{2}$ " below the bottom of the starter strip. This can be done with a plumb line as a level. If more than one post is needed to reach the desired height be sure to overlap the bottom corner with the top corner. Be sure to install nails every 12" on both nailing areas. Do not over tighten screws or drive nails too deep to avoid distortion. Make sure the corner base is installed squarely to the wall, this will add to the final appearance of the job. Once the base is installed, cut your siding to fit tightly into the pocket and then add the cap to finish it off. Attach one side of the cap to the base along the full length, and then work the other side in. No nails are needed to install the cap (Figure 14.1).

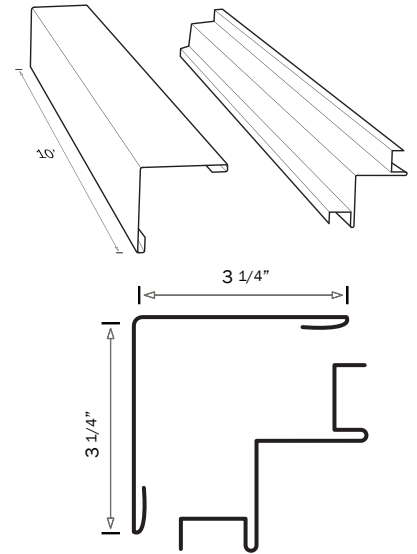

Figure 14.1

J Block Installation

Utility J-block Installation Video (Starts at 7:35)

www.youtube.com/watch?v=0KzYbWhjE3g

Light J-block Installation is identical to the Utility J-Block method.

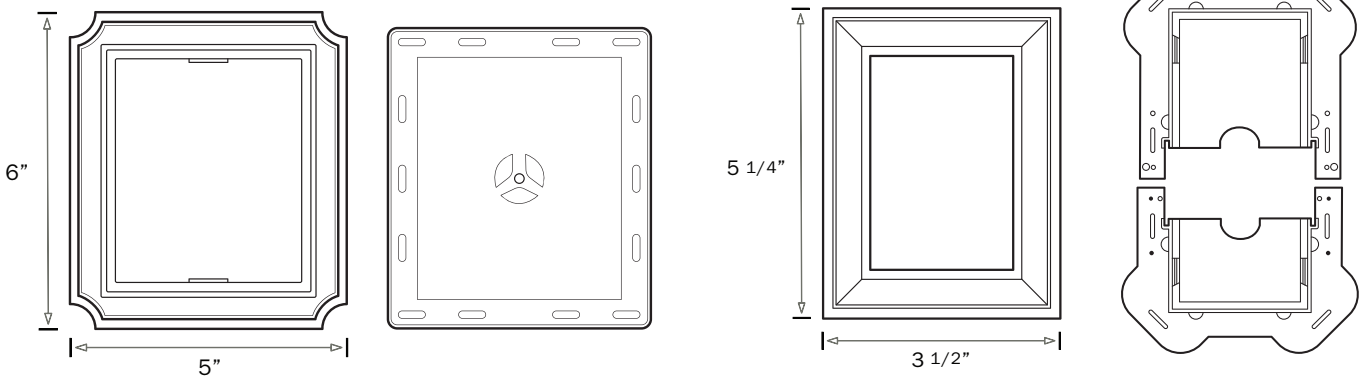

Steel Siding Cutting

Power Saw

Steel siding may be cut with a carbide tip saw blade that is specifically designed for cutting steel. You can use a ferrous or non-ferrous metal cutting blade. The more teeth on the blade the better for a cleaner cut. For the lap siding, start your cut at the top lock/nail flange. Get your blade started in there and pull the miter saw towards you nice and smoothly.

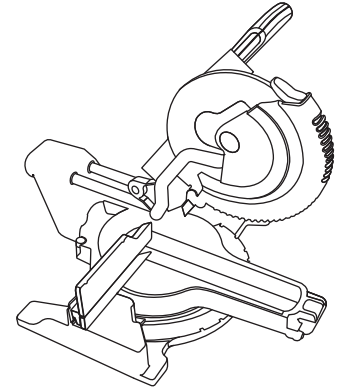

Tin Snips

Tin snips may be used to cut siding (**Figure 15.1**). Start by drawing a straight line on the siding with a speed square. Then start cutting from the lock edge first working downward through middle butt carefully, Continue downward, snipping through and around the bottom lock. Then use a screwdriver to re-open the lock edge and bottom locking edge. Tin snips are also used to cut J-channels, finish trim, and O.C.P.

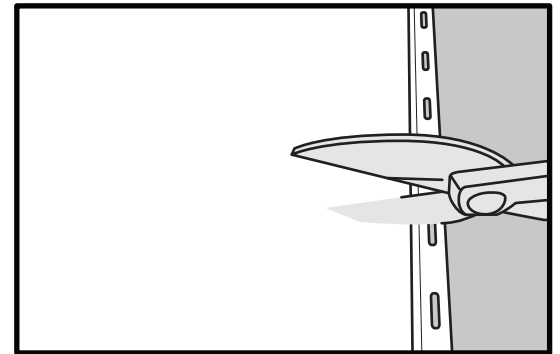

Figure 15.1

Electric Shear

This tool may be used for length wise cuts across face of siding. Especially helpful for window and door cuts (**Figure 15.2**).

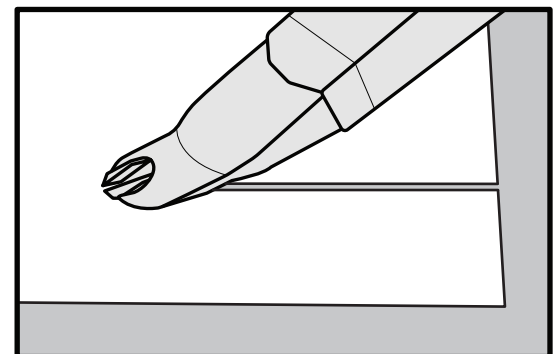

Figure 15.2

Siding Termination Method

Steel Board & Batten Termination Method

The vertical Board & Batten panels will terminate into a J-Channel at the top of where your wall meets your soffit. If you have cut the board & batten panel to fit, make sure the cut edge goes into the termination J-Channel and the factory cut edge sits on the Rat Stop/Starter below. (**Figure 16.1**)

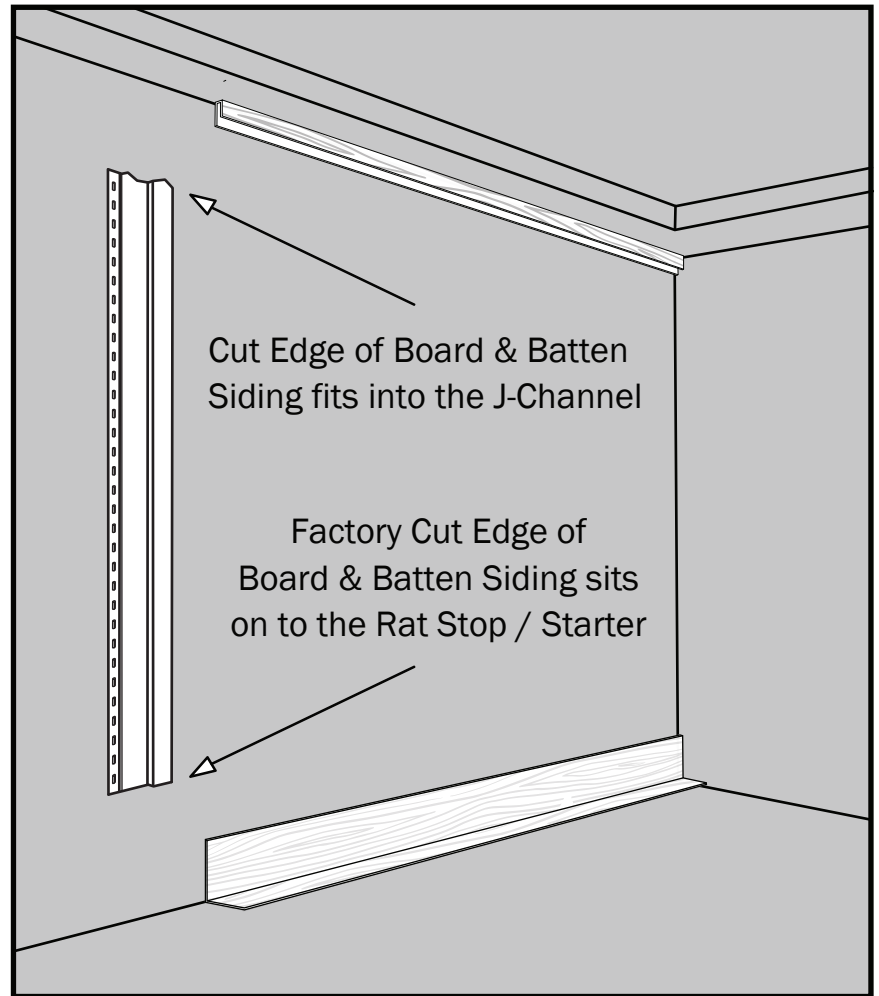

Figure 16.1

Panel Installation

Starting Your Siding

Take a measurement of your wall from the inside of the termination J-Channel at your soffit down to the Rat Stop/Starter you installed. Now take your first panel, make sure it is measured to the proper length. If not, cut the panel to the measurement you made on the wall and leave it short $\frac{1}{8}$ " so it can fit into the J-channel at the top. **(Figure 17.1)**

Once you have the panel cut to the correct length, slide the cut edge into the termination J-Channel. Next, rest the bottom of the panel on the Rat Stop/Starter. Make sure the panel is also touching the inside of the J-Channel or corner on the side, where you are starting. **(Figure 17.2)**

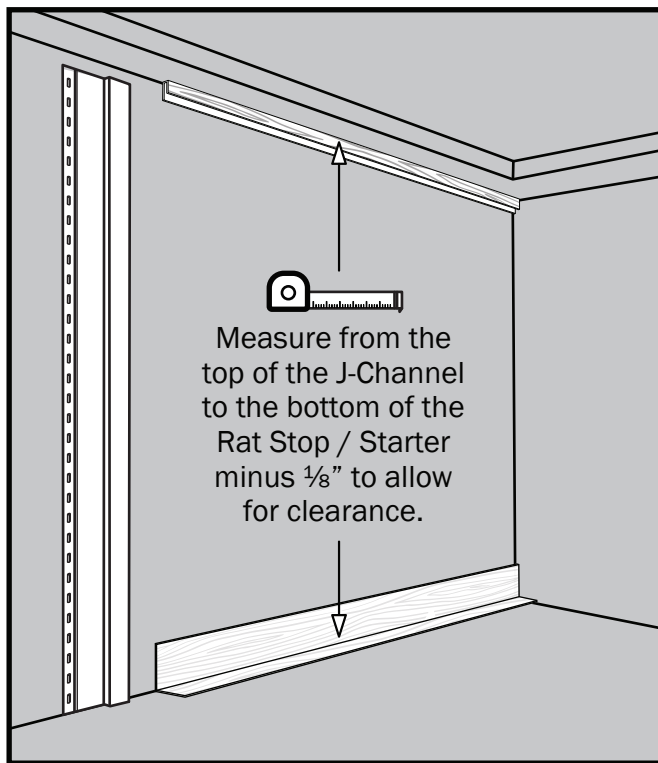

Figure 17.1

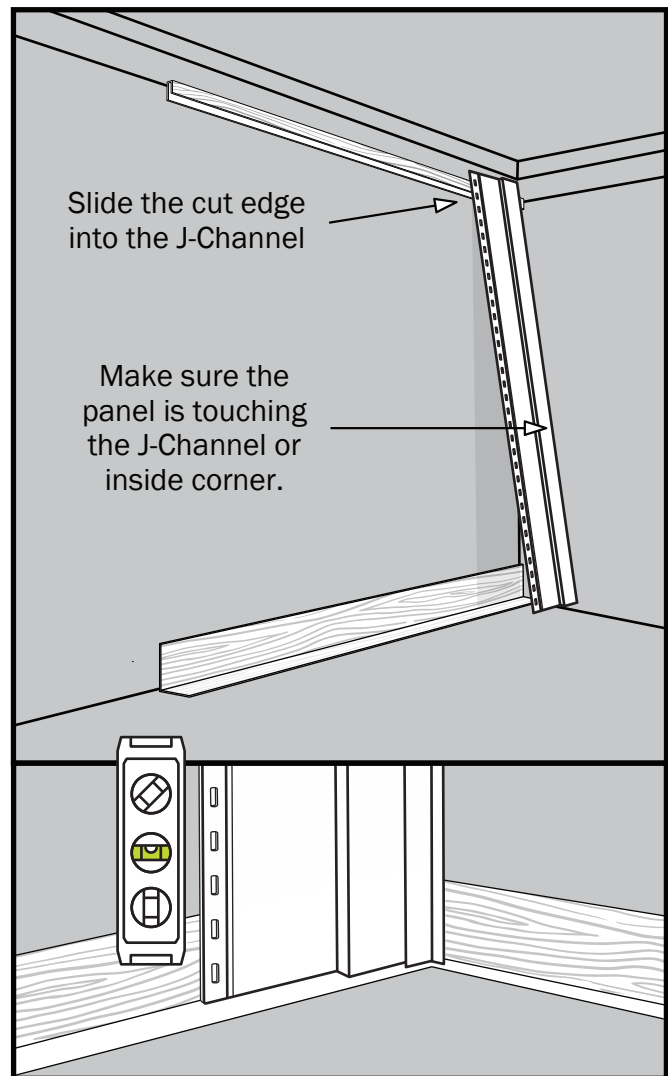

Figure 17.2

Panel Installation

Corner Cap Installation

Install your corner base directly on the bare corner and use screws to fasten it to the wall. **(Figure 18.1)**

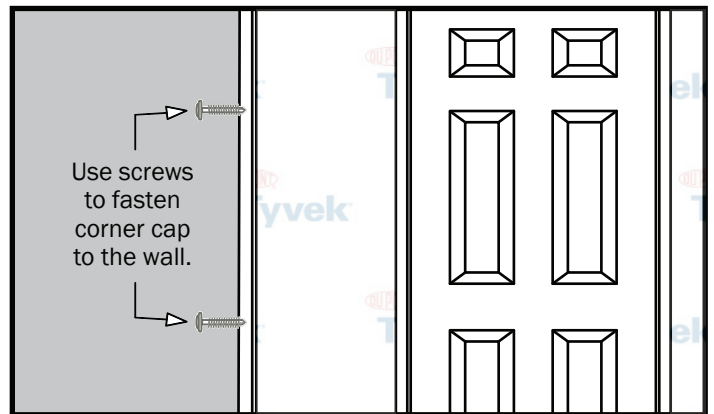

Figure 18.1

Hanging of Siding

When placing screws or nails through the factory slots be sure to place your screw or nail in the center of the factory slot. Screw or drive a nail into the flange while taking precaution not to drive in too tight. By doing this you will allow the siding to expand and contract freely with the temperature changes and eliminate any waving or buckling. **(Figure 18.2)**

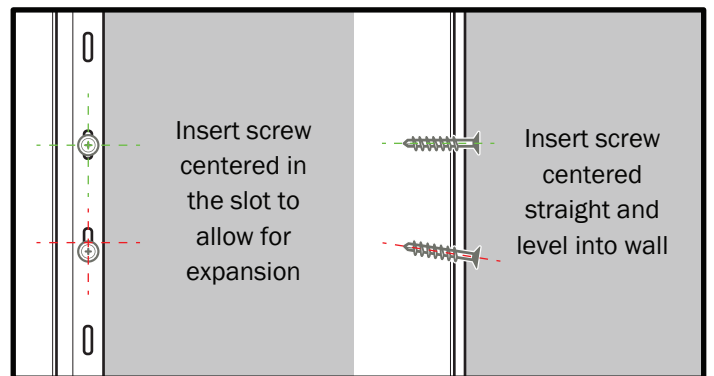

Figure 18.2

Locking Siding Panels

Insert and slide the next panel to lock. Two properly locked panels should have a distance of $6\frac{3}{4}$ " between battens. We suggest that you make three guide templates from wood cut to $6\frac{3}{4}$ ". The guide wood should be used at the top, middle, and bottom of the panels to make sure that they are locked together properly. Once you get the hang of things you can usually check visually to see if the panel is locked correctly and you can start to feel the panel bottom out and "snap" into place. **(Figure 18.3)**

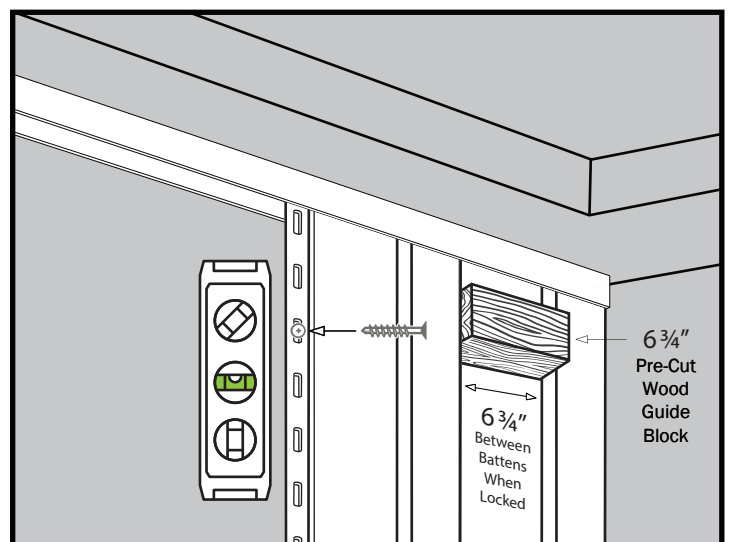

Figure 18.3

Panel Installation

Panels at Window and Doors

When installing siding around windows and doors you will need to cut the siding to fit. Measure the height and width of the space you need under and above the window or door and transfer those measurements to cut the left and right side panels with cut outs removed as well as any short panel sections needed to fill the space above or below. **(Figure 19.1)**

***Note: Be sure to measure both sides of the window, you may find some openings are not always level.**

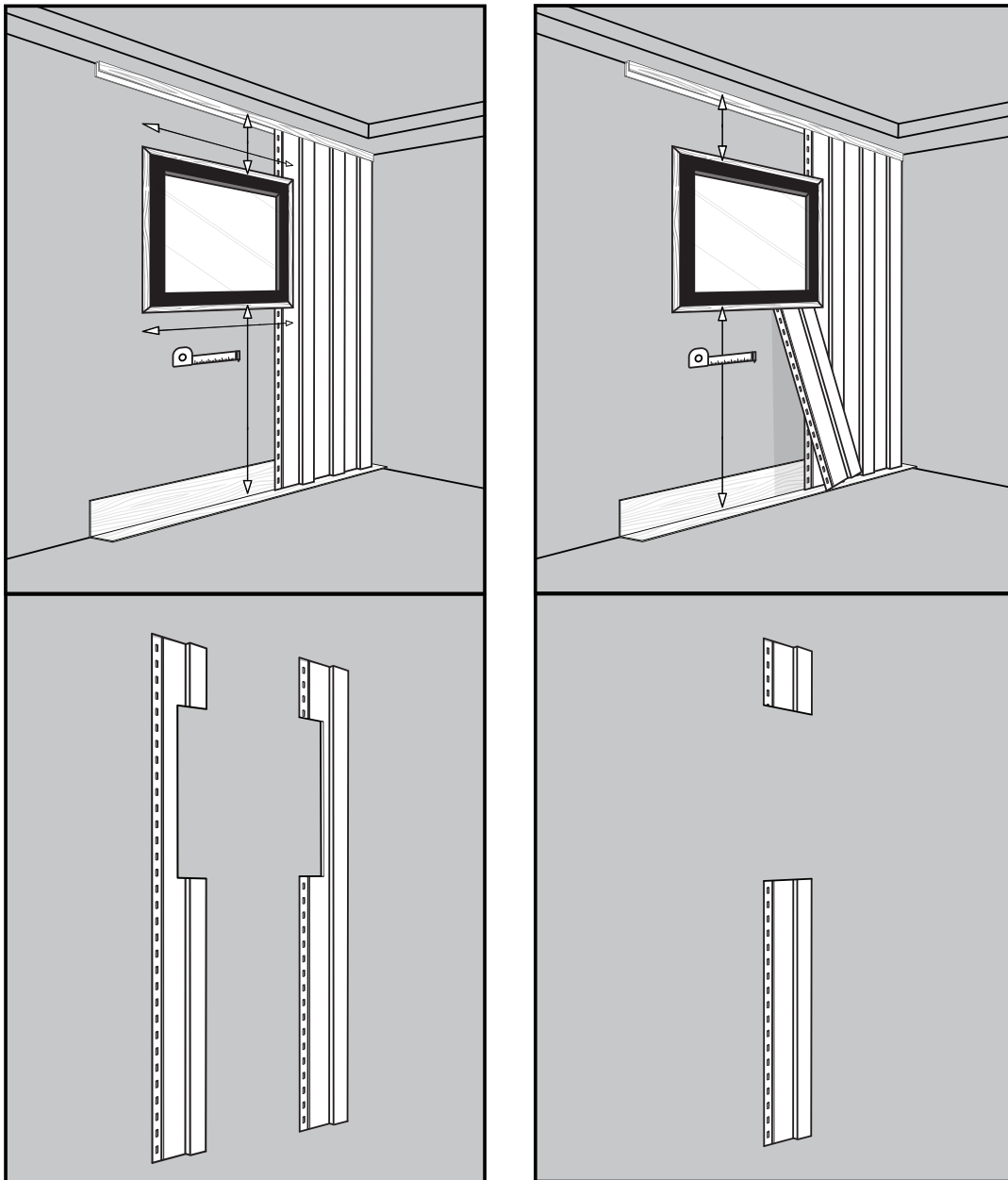

(Figure 19.1)

Panel Installation

Bold Band Board Installation

The Bold Band Board is used to transition from one level of the Board & Batten panels to an upper level. You mostly see this where your side walls transition into your gable or where you have one wall that is taller than another. The “Z-Metal” or Bold Band Board sits on top of the lower level of panels as a cap and also acts as the starting point to install an upper level of panels. **(Figure 20.1)**

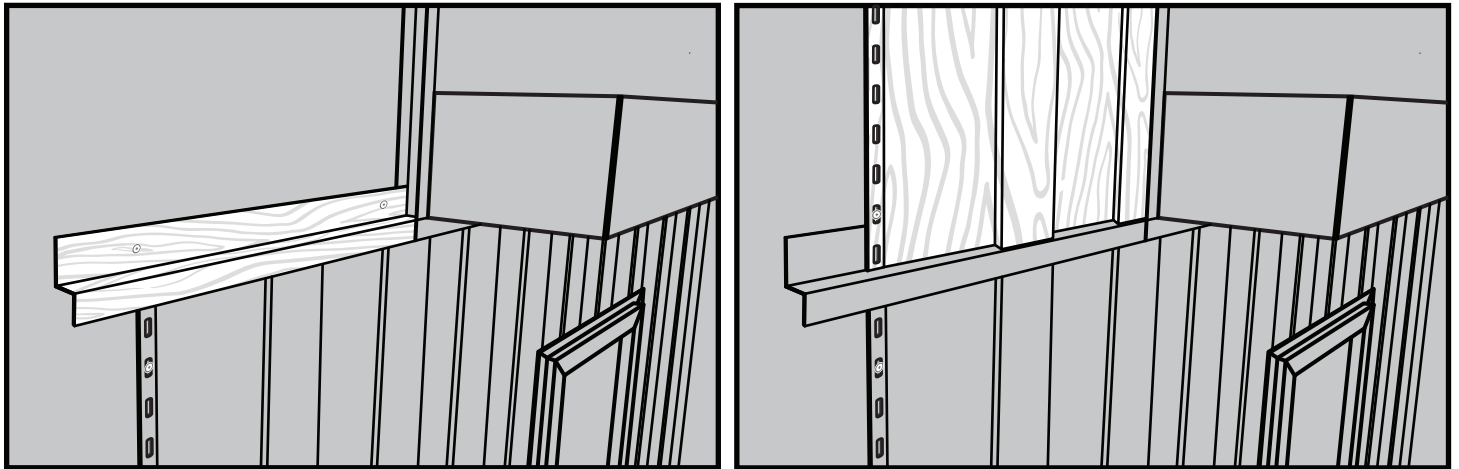

(Figure 20.1)

Inside and Outside Corner Panel Installation

When finishing off a wall and terminating your panel into the corner base, you may have to rip the panel down from top to bottom in order to fit flush to the wall. If you run into a situation where the 9¼” panel won't fit flush you can trim the panel from the nail slot side to the correct width. Once the panel is cut, install the Sill Trim over the cut edge and install. **(Figure 20.2)**

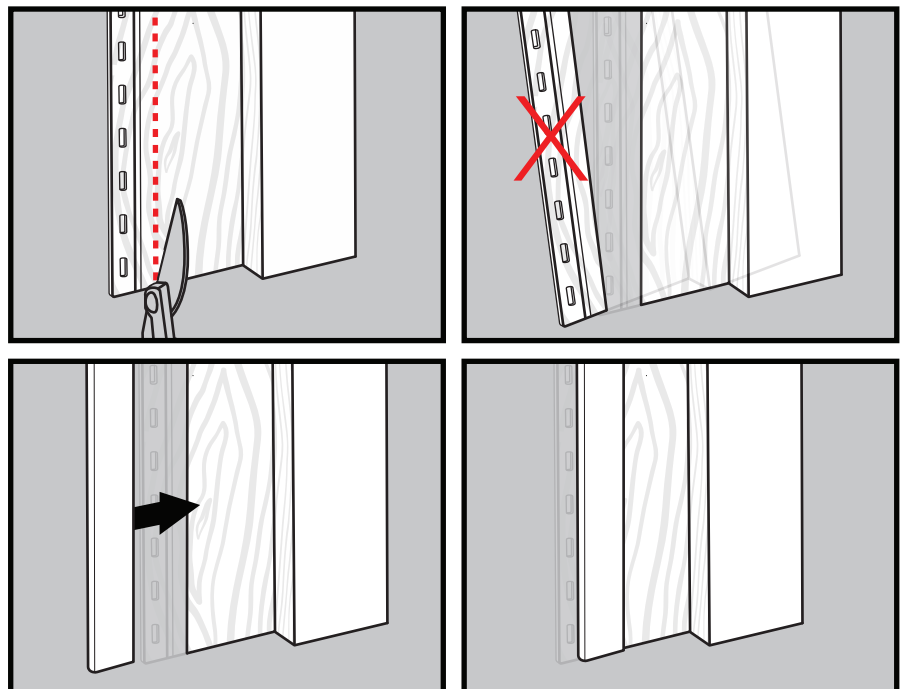

(Figure 20.2)

Panel Installation

Clean-Up

Use a mild soap and water for clean-up with a soft cloth or sponge. Do not rub excessively, this could cause damage to the surface. Do not use harsh abrasives. Mineral spirits may be used sparingly to remove grease or asphalt stains.

Job Site

Re-install all fixtures and wires that were removed prior to installation. Scrap pieces, siding boxes, nails, debris, etc. should be removed daily.

Additional Tips

It may be necessary to leave J-channels or corner posts loose around openings to help for installation of short siding panels. You may also have to leave J-channels off to get short pieces in and slip a J-channel in after installation. Nailing for this procedure can be done into the back side of the J-channel at every other row into the casing which it is butted into. A nail set will help in this procedure to set your nails into the wood. If leaving J-channels loose bow out ends and slip siding into J-channels and lock together.

TruLog™

MAINTENANCE-FREE STEEL SIDING

20684 Niobrara Blvd. • LaSalle, CO 80645

970-646-4490

info@trulogsiding.com • www.TruLogSiding.com



facebook



instagram



pinterest



houzz



Patented Profile and
Registered Trademark